

trivum troubleshooting

Troubleshooting

1. List of recent software changes	9
2. Recent known issues	9
2.1. Qobuz play failure with error 112	9
2.2. Unexpected V10 USBC cable connection errors	9
2.3. Deezer playlist stops playing, Eventlog shows Track not available	10
3. Red blinking, device is showing a red error light, or red and other color	10
3.1. RP311v2/RP321/RP341v2/SC340m is blinking red and yellow alternatively	10
3.2. RP311v2/RP321/RP341v2 is just blinking red	10
3.3. RP311v2/RP321/RP341v2 permanent RED light at Power Connector(s)	10
3.4. SC311m is blinking red fast twice every second	10
3.5. SC311m/SC340m is blinking yellow slow once per second	11
3.6. SC311m cannot be used showing IP 192.168.99.73	11
4. Network related issues (blocked UDP multicast)	11
5. trivum App cannot find trivum devices in the network	11
5.1. Problem:	11
5.2. Solution:	11
5.2.1. Correct the WLAN access	11
5.2.2. Find the trivum-IP address by other ways, and use trivum by browser	12
6. AirPlay Inputs cannot be found in a network	12
6.1. Problem	12
6.2. Solution	13
7. AirPlay Inputs cannot be connected	14
7.1. Problem	14
7.2. Solution	14
8. AirPlay inputs are not visible in a company network	14
8.1. Problem	14
8.2. Solution	14
9. Spotify Connect inputs cannot be found in the network	15
9.1. Problem	15
9.2. Solution	15
10. KNX IP Router cannot be found or sends nothing	16
10.1. Problem	16
10.2. Solution	16
11. KNX IP Router sends KNX temporary and then nothing	18
11.1. Problem	18
11.2. Solution	18

12. Master/Slave cannot be combined	19
12.1. Problem:	19
12.2. Solution:	19
13. No sound on group play with many devices	20
13.1. Problem:	20
13.2. Technical background:	20
13.3. Solution:	21
14. Network failure on group play	21
14.1. Problem:	21
14.2. Solution:	21
14.3. Possible problems of network topology at the customer:	23
14.4. Configuration of further switches:	23
15. WiFi multicast settings with a Ubiquiti Unify Switch	24
15.1. traffic across different subnets (VLAN's)	26
16. WLAN Errors while streaming Audio with trivum devices	26
16.1. Problem	26
16.2. Solution	26
17. AirPlay sound dropouts	27
17.1. Problem	27
17.2. Solution	27
18. Further issues (not UDP multicast related)	27
19. FM radio reception disabled by cable provider	27
20. DAB no audio reception	28
21. Cannot find option to hide default Stream, Tuner or LineIn actions	29
22. Search is not possible in WebUI	29
23. Spotify plays in zones unexpectedly	29
23.1. Possible reasons	29
23.2. Solution 1: restrict playback start to specific accounts	30
23.3. Solution 2: disable zone activation on playback start	30
24. Bluetooth cannot be paired/played with AudioBox P150	31
25. RP341v2 permanent blue light	31
26. RP311v2 RP321 RP341v2 actuators are blinking purple/violet	32
27. RP341v2 Fuse channel 2+4 broken (code 2000)	32
28. RP341v2 no sound on all outputs	32
29. RP341v2 no sound on outputs 1 and 2	32
30. RP3xx channel overload	33
31. RP310 no sound	33
32. RP311v2 no DAB audio due to swapped antenna wires	34
33. If TIDAL account setup does not complete	34
34. If TIDAL does not play	34
35. Divus KiBro App does not work	34

36. No TuneIn Menu, Error 403 in TuneIn plugin	35
37. No access to TuneIn favorites	35
38. TuneIn stations do not play with V8 software	35
39. V8 and V9 devices are not compatible.....	35
40. InStreamer: if Digital Input has no sound:	36
41. InStreamer: if Digital Input is distorted:	36
42. InStreamer Update Fails.....	36
42.1. How to check:	37
42.2. How to fix:	37
43. Distorted, cracking or interrupted sounds.....	37
43.1. Reason	37
44. The sound is interrupted every few seconds	37
44.1. Reason	37
44.2. Solution	38
45. StreamSource card hangs until restart with no audio	38
45.1. Problem.....	38
45.2. Solution	38
45.3. Repair service	38
46. No sound from some StreamSource cards.....	39
46.1. Problem.....	39
47. Short Sounds may not play correctly	39
47.1. Problem.....	39
47.2. Solution.....	39
48. AudioBox P150 sound dropout every 2 seconds.....	40
48.1. Problem.....	40
48.2. Solution.....	40
49. Digital Line Input / TOS Link no sound or just noise.....	40
49.1. Problem.....	40
49.2. Solution.....	40
49.3. Problem.....	40
49.4. Solution.....	40
50. RP341/RP340 power connection how to	41
51. 4 Zone Actuator, RP341/RP340 no sound in zones 3 and 4.....	41
51.1. Problem.....	41
51.2. Solutions.....	41
51.2.1. Insufficient power supply.....	41
51.2.2. Defective Fuse	41
52. RP311v1 Fuse 1 broken error	42
52.1. Solutions.....	42
53. Spotify Connect Inputs are not visible with group play	42
54. AirPlay cannot be used from a Desktop Mac or PC	42

54.1. Problem	42
54.2. Solution	42
55. Unexpected Zone On with unexpected music play	43
55.1. Problem	43
55.2. Solution	43
56. SpotifyConnect changes volume on next track	43
56.1. Problem	43
56.2. Solution	43
57. SpotifyConnect switches zone on unexpectedly	44
57.1. Problem	44
57.2. Solution	44
58. SpotifyConnect volume goes up unexpectedly	45
58.1. Problem	45
58.2. Solution 1	45
58.3. Solution 2	45
59. SpotifyConnect shows only one input with SC	45
59.1. Problem	45
59.2. Solution	46
60. Cannot update / no internet or nameserver	46
60.1. Problem	46
60.2. Solution	46
61. Bad sound with stereo speaker	47
61.1. Problem	47
61.2. Solution	47
62. Bad sound when standing between two speakers	47
62.1. Problem	47
62.2. Solution	47
63. How to configure the speaker db switch	47
64. C4 master computer is not reachable after power outage	48
64.1. Problem	48
64.2. Solution	48
65. Controller C4 is down although cabling is correct	48
65.1. Solution	48
66. Crestron fails to send commands to trivum after a while	48
66.1. Problem	48
67. DHCP Server cannot be reached	48
67.1. Problem	48
67.2. Solution	49
68. Fuse Broken	49
68.1. Problem	49
68.2. Solution	49

69. Zone is undefined	49
69.1. Problem	49
69.2. Solution	49
70. AirPlay unwanted zone activation on track change	50
70.1. Problem	50
70.2. Solution	50
71. AirPlay Startup Errors	50
71.1. Problem	50
71.2. Solution	51
71.3. Aternative	51
72. WebTouch Visu does not show on a TouchPanel PC in an iframe	51
72.1. Problem	51
72.2. Solution	51
73. WebTouch Visu does not work correctly on TouchPanel PC	52
73.1. Problem	52
73.2. Solution	52
73.2.1. Windows XP/Vista/7	52
73.2.2. Windows 8	52
74. Resource sharing conflict	52
74.1. Problem	52
74.2. Solution	53
75. Unexpected source (music file/webradio) appears after switching sources	53
75.1. Problem	53
76. TuneIn uses wrong city or country location	53
76.1. Problem	53
76.2. Solution	53
77. Red LED light is permanently active after Software Update on AudioActuator	54
77.1. Reason 1: Incorrect flashing	54
77.2. Solution	54
77.3. Reason 2: Jammed reset Button	54
77.4. Solution	54
78. 4Zones Actuator: Voltage too low Alert	54
78.1. Problem	54
79. simulateKeyPress must be called twice	55
79.1. Problem	55
79.1.1. Solution	55
80. Group Play with external volume control does not work	55
80.1. Problem	55
81. No sound from some StreamSource cards	55
81.1. Problem	55
82. Webcam authorization error	56

82.1. Access by user/password not possible	56
83. NAS access to a Windows PC share requires username	56
83.1. Problem	56
83.2. Solution	56
83.3. Windows 10 firewall issues on share access	56
84. Change audio volume without a slider by defining + and - actions	57
85. How to identify trivum Components by Serialnumber	57
86. SC LED light blink codes or patterns	57
87. Actuator LED light blinks with codes or patterns	58
88. The red LED of an Actuator is permanently active on first use	58
89. The red LED of an Actuator is permanently active after a Software Update	59
90. RP010 specific LED behaviour on startup	59
91. create Windows Desktop Shortcut to Web Visualization	59
92. How to control multiple Actuators or AudioBoxes via one Web Visualization	60
93. Maximum possible Streams (StreamSources) per device	60
94. C4 with 2 or more Cardhosts: Noise or unexpected sound	61
94.1. Problem	61
94.2. Solution:	61
95. How to test if a card is broken	61
95.1. Problem:	61
95.2. Solution:	61
96. 4 Zone Actuator: Amplifier channel overload	62
97. Web Visu Volume Slider Error with Chrome on TouchPanel PC	62
98. number of wires required in a LAN connection cable	63
99. how to reduce the Web UI elements	63
100. Invalid NAS reply while scanning music files	63
101. No sound, no radio reception with FM Tuner	64
102. 4 Zone Actuator Power Supply Connection	64
103. Line Input Auto Sensing: signal without sound too high	64
103.1. Problem	64
103.2. Solution	64
104. Line Input Auto Sensing with analogue audio: unexpected activation	64
104.1. Problem	64
104.2. Reason	65
104.3. Solution	65
105. Spoken text is very silent, while music plays normal	65
105.1. Problem	65
105.2. Solution	65
106. SC344 or SC340 red or green blinking on startup	65
107. Device is not reachable by network, fully offline	66
108. Cannot call trivum Android app from another app	66

109. V10 Web Setup Alert: the selected line audio input is not enabled	66
110. trivum Touchpad related articles	67
111. Some Touchpads freeze after long runtime	67
112. Touchpad has no network connection	67
113. Touchpad network failure with static IP	67
114. How to update Touchpads via the MusicServer	68
115. A webcam image appears and freezes for several seconds on TouchPad	68
115.1. Problem	68
115.2. Solution	68
116. Cannot use Touchpad or iPad during group play	69
116.1. Problem	69
116.2. Solution	69
116.3. TouchPad alarm icon shows no time	69
117. TouchPad time differs from trivum Server	69
118. TouchPad cannot be opened by web browser	70
118.1. Problem	70
118.2. Solution	70
118.3. Special case	70
119. TouchPad does not accept touch presses in some areas	71
119.1. Problem	71
119.2. Solution	71
120. TouchPad does not accept touch presses anywhere	71
120.1. Problem	71
120.2. Solution	71
121. RGB dimmer color wheel is not shown on TouchPad	72
121.1. Problem	72
121.2. Solution	72
122. No webcam image appears on TouchPad	72
122.1. Problem	72
122.2. Solution	72
123. cannot delete web radio favourite with touchpad	72
123.1. 7 inch touchpad compatible POE switches	73
123.2. 7 inch touchpad startup failure	73
124. Touchpad: no rows/system/data found error	73
125. Music purchased through iTunes cannot be synchronized to the trivum System	74
125.1. Problem	74
125.2. Solution	74
126. iTunes database on NAS does not use Library.xml	75
126.1. Problem	75
126.2. Solution	75
127. Known issues with V8/C4 systems only	75

128. Zone Actions cannot be edited	75
128.1. Solution	75
129. RS232 Adapter can be listed but not connected/programmed	75
130. IR/RS232 Adapter power supply connection	76
131. How to trace IR/RS232 Adapter communication	76
131.1. activate device I/O tracing at server side	76
131.2. trace communication directly at the Adapter	77
131.3. control the device manually	78
131.4. Typical RS232 Adapter replies	78
131.4.1. RS232 Adapter V 1.03 examples:	78
132. Devices at IR/RS232 Adapter do not react	78
132.1. Adapter is not active, not found in network	79
132.2. Adapters are detected	79
132.3. Possible test	79
132.4. Connection from RS-232 adapter to device	79
133. Known issues with old system configurations	80
133.1. TIDAL account update required from 09.11.20	81
133.2. Spotify access shows error: need premium account	81
134. Coverart does not show in Audioplayer screen	81
134.1. Problem	81
134.2. Solution	82
135. Known issues with old software versions	82
135.1. Web Radio or Audio Service stream interrupted after some time	82
135.2. Web Radio stations do not play	82
135.3. AirPlay with iOS9 requires V8.68 software or higher.	82
135.4. AirPlay problem with C4 on 2nd, 3rd streamsource card:	82
135.5. Spotify App cannot be opened from within the trivum iOS App	83
135.6. No sound on group play with SC and AudioBox P150 devices	83
136. Weather forecast requires Touchpad V2.11.	83
137. Empty Web Visualization with iOS 9.3.5 iPad, iPhone, Safari browser	83
138. RPx actuators: if unexpected restarts occur:	83
138.1. Cannot search in the trivum Android app	83
138.2. trivum Android app volume control not reachable	84
138.3. No sound with newer SC344m devices	84
138.4. direct software update not possible with some devices delivered in autumn 2022	84
138.4.1. Solution: update twice	84
138.5. Touch control does not work in the web user interface	84
138.6. trivum App for iOS V2.5.0 cannot be used with old iOS versions	85
138.7. No control on iPad with old V8 software and iOS 15.4	85
138.8. V8 systems WebUI failure	85
139. /xml/zone/runCommand.xml for TuneIn Favorites does not work	85

139.1. Problem	85
139.2. Solution	85
140. Static IP cannot be configured with AudioActuator	86
140.1. Problem	86
140.2. Solution:	86
141. Further reading	86
141.1. Gira HomeServer and QuadClient issues	86
142. Appendix	86
142.1. AirPlay message analysis with sfk.exe	86
142.2. SpotifyConnect message analysis with sfk.exe	88

1. List of recent software changes

If you have a an issue with your trivum system, always take a look if it was fixed already here:

- [MusicCenter changelist V9](#)

Changes listed here are done normally in V9 and V10 software in parallel.

- [MusicCenter changelist V10](#)

Sometimes changes are done in V10 only, and then listed here.

- [Touchpad changelist](#)

2. Recent known issues

2.1. Qobuz play failure with error 112

Please update to software 9.81 or 10.09 build 17567.

2.2. Unexpected V10 USBC cable connection errors

If you configure USBC cable connections with SC344m devices and connect everything correctly, but an error appears:

"Connection is defined, but no real wire is connected"

the reason can be the cable itself. Plug the cable out at one end, turn it 180 degrees, plug it in again. If the cable is just partly damaged, this can help. If it doesn't help, replace it by a different cable.

Please note that trivum devices require high quality USBC cables:

- implementing the USB 3 standard or higher. USB 2.0 is insufficient.
- it must be a data cable, supporting 5-10 gbit/sec speed. (with charge-only cables there will be no

sound.)

- they must have extra wires for Video and Audio, or "DP Alt Mode" (DisplayPort). without that, automatic cable detection will fail.

2.3. Deezer playlist stops playing, Eventlog shows Track not available

The playlist contained references to old track ID's which are no longer available. The software now uses alternative ID's automatically. Update to the latest software version.

3. Red blinking, device is showing a red error light, or red and other color

3.1. RP311v2/RP321/RP341v2/SC340m is blinking red and yellow alternatively

This means the network cable connection is broken. Replace the LAN cable, and/or try a different port at the network switch, then press the reset button on the trivum device.

3.2. RP311v2/RP321/RP341v2 is just blinking red

This means the device software is no longer starting.

Maybe the SD card got loose. Take the device from power, and open it. Remove the SD card (remember it's orientation). Reinsert the SD card. Reconnect device power.

If that does not help, contact trivum support.

3.3. RP311v2/RP321/RP341v2 permanent RED light at Power Connector(s)

There are small LED's directly at the power connectors, which are normally off.

If they show a permanent red light it means the power was connected with wrong polarity! Disconnect the power immediately and double check which is the + and which the - cable.

3.4. SC311m is blinking red fast twice every second

This means the network cable connection is broken. Replace the LAN cable, and/or try a different port at the network switch, then press the reset button on the trivum device.

3.5. SC311m/SC340m is blinking yellow slow once per second

If the device is blinking in red during startup, and after 1-2 minutes, blinking yellow permanently, this means the device software is no longer starting.

Maybe the SD card got loose. Take the device from power, and open it. Remove the SD card (remember it's orientation). Reinsert the SD card. Reconnect device power.

If that does not help, contact trivum support.

3.6. SC311m cannot be used showing IP 192.168.99.73

In some cases a SC311m showed in ServerAdmin tool with an unexpected IP 192.168.99.73, and no longer reacted to any tries to change the network configuration. This probably happened after setting static IP, maybe combined with WLAN activation.

If you can no longer access the SC311m by network, reset the network interface: - press **Src and Power** together, until the status LED blinks red. Release the keys. - the system will restart, and the network interface is reset to DHCP.

4. Network related issues (blocked UDP multicast)

5. trivum App cannot find trivum devices in the network

5.1. Problem:

the trivum App for iOS or Android does not list trivum devices in the network.

This is a network problem. trivum devices are found by receiving multicast hello messages. Network components like Router, Switches, or WLAN access points may block these messages.

5.2. Solution:

5.2.1. Correct the WLAN access

- compare the IP of your mobile device to the trivum IP, if they are in the same sub network, like 192.168.178.x.
if a network is split into subnets or VLANs with different IP ranges, e.g. 192.168.1.x versus 192.168.2.x, then by default all device discovery is broken.
The sense of subnets is to block traffic, especially multicast UDP traffic. It is then required to add

rules (routes) at the network switch or router to pass the discovery traffic through.

- try different WLAN access points. for example, if you go with your device from room to room, it may switch between access points, and it with one of those access points it may work.
- make sure to use a WLAN access point which is directly connected to the switch where trivum is connected, or which is integrated into that switch or router.
- check the configuration of your network WLAN access points, network switches, and the router. Allow UDP multicast traffic from LAN to WLAN. Allow it either general, or specifically for

```
group 239.255.84.83 port 4002    (main discovery)
group 224.0.0.100  port 4002    (alternative discovery)
```

- the WLAN router may need a firmware update.
- make sure that network access is not blocked for the trivum app on your mobile device. try to uninstall and reinstall the trivum app.

5.2.2. Find the trivum-IP address by other ways, and use trivum by browser

- on a Windows PC, download and install the trivum-IP finder. it is available on service.trivum.com. Connect your PC/Notebook by LAN cable (disable WLAN) to the same switch as trivum. It will show the IP address of the trivum device.
- you may also look into the web configuration of your network router to find the trivum-IP address.

Then open a normal web browser on your mobile device, like Google Chrome, and type that IP address to use your trivum system without the mobile app. Add a bookmark to reopen it more easily.

With the trivum app for Android you may also enter the found IP manually.

Please note that, with DHCP, the trivum-IP may change at a later time. If that occurs too often you may reserve an IP for trivum in your router configuration, or consider setting a fixed IP in the trivum setup.

See also: [WiFi multicast settings with a Ubiquiti Unify Switch](#)

6. AirPlay Inputs cannot be found in a network

6.1. Problem

trivum AirPlay inputs are not listed on an iPhone.

6.2. Solution

- the WLAN network could be the problem.

Try to use AirPlay via normal LAN cable.

To do so, install iTunes on a PC or Mac, then click on the blue speaker selection symbol, at the top, right to the volume bar.

If trivum AirPlay inputs are shown there then it is a problem of your WLAN switch, router, or access point.

For example:

- the WLAN router may be configured not to send multicast messages into the WLAN. Check your router configuration.
- the WLAN router may need a firmware update. In rare cases, routers are blocking multicast before the update, and passing through multicast after an update.
- some WLAN access points like Aruba WiFi AP controller have extra options in their configuration to enable bonjour and airplay messages in the network.
- maybe the WLAN router needs to be replaced by a different WLAN access point.
- **Activate the trivum workaround for message blocking networks:**
in the trivum web configuration, under trivumip/setup, go to :
music / streaming / airplay / send zone names repeatedly
and select: send zone names every minute
- a network using multiple sub networks like, for example
subnet 192.168.1.x via cable
subnet 192.168.3.x via WLAN
will normally block **all** multicast traffic **by default**, allowing no Airplay, no detection of any trivum device by the trivum iphone app or ServerAdmin tool, and no KNX IP router traffic!
in such cases tell your network administrator to configure
 - full send-through of bonjour protocol messages via multicast group 224.0.0.251 port 5353 in both directions:
 - from WLAN to LAN for Bonjour Discovery Requests
 - from LAN to WLAN for Bonjour Discovery Replies
 - full send-through of trivum discovery messages via multicast group 239.255.84.83 port 4002 and via multicast group 224.0.0.100 port 4002 at least from LAN to WLAN
 - full send-through of KNX messages via multicast group 224.0.23.12 port 3671 in both directions
- Also compare with other (non trivum) devices that support AirPlay. For example, try to stream music to some Apple AirPlay speakers. If their inputs do not show up, or are lost after some time, then there is a network problem.
- While your client application (e.g. an iPhone App) is running, open the Multiroom Setup Tool and select Admin → Quick Restart. The server does not permanently announce its AirPlay inputs but only from time to time. By restart you enforce an immediate sending of these announcements

See also: [WiFi multicast settings with a Ubiquiti Unify Switch](#)

7. AirPlay Inputs cannot be connected

7.1. Problem

trivium AirPlay inputs are listed, can be selected at first, but when trying to play audio, it shows a popup "connection not possible".

7.2. Solution

this occurs if someone else is streaming to the same network input, with a different device.

8. AirPlay inputs are not visible in a company network

8.1. Problem

Company networks are designed for maximum security, including network segmentation

- by using different IP ranges on different ports on the router
- and/or by using VLAN's

For example, the main company PC's can be in a VLAN with IP range 192.168.1.x, audio devices in a VLAN with IP range 192.168.2.x, and mobile devices in a WLAN with IP range 192.168.3.x.

By default, security means that every traffic between the network segments is blocked. The mobile devices cannot see Airplay inputs because every UDP message, including Bonjour multicast messages, is blocked between the audio segment and the WLAN segment.

For a comparison, connect a Windows PC by LAN cable to the same switch as trivium. Make sure no WLAN is active, and that it is in the same IP range as trivium. Then install iTunes on the PC. The trivium AirPlay inputs must appear therein.

That means, AirPlay inputs are visible in the same network segment, but not in a different one, e.g. WLAN.

8.2. Solution

The network administrator must configure exceptions, or bridges, between the segments:

- 1) Bonjour UDP Multicast queries must be passed from the WLAN segment to the audio segment
- 2) Bonjour UDP Multicast replies must be passed from the audio segment to the WLAN segment

depending on the firmware running on the network devices (Router, Switch, Controller) this can be achieved by options named "Bonjour", or by directly passing UDP messages for multicast group 224.0.0.251 port 5353. Some WLAN access points like Aruba WiFi AP controller have extra options

in their configuration to enable Bonjour and AirPlay messages in the network.

If only case 1) is blocked, there is a workaround option on trivum devices to send AirPlay input names cyclically, even without getting a query. In the trivum web setup, go to: Music / Streaming / AirPlay, and activate: Send zone names repeatedly / send zone names every minute.

But if that does not help, consult the network admin.

Configuring Bonjour bridges may not be sufficient. If the AirPlay inputs are shown and can be selected, but subsequent play fails, then either full UDP and TCP traffic between audio and WLAN segments must be allowed, or the WLAN and audio segment must be joined into the same VLAN.

Further reading:

[Spotify Connect inputs cannot be found in the network](#)

[trivum App cannot find trivum devices in the network](#)

[AirPlay message analysis with sfk.exe](#)

https://www.trivum.com/trivum/docs/en/trivum-faq.html#_airplay_inputs_in_brackets_cannot_be_used

9. Spotify Connect inputs cannot be found in the network

9.1. Problem

in the Spotify client for mobile phone or tablet, no trivum inputs are visible.

9.2. Solution

In a few cases this can be a configuration problem, like Spotify Connect not being enabled on the trivum system, or the Spotify App on your mobile was not given the right to look for devices in your network.

But in most cases, it is a network problem: **the network is blocking UDP multicast messages.**

- the WLAN network could cause that problem.

Try to use Spotify Connect via normal LAN cable.

To do so, install Spotify on a PC or Mac which is connected by LAN cable to the same network switch as trivum. If the PC/Mac also has a wireless interface make sure it is disabled. All traffic must go through cable only.

Ideally the network switch is a simple, unmanaged model like TP-Link 1008P.

(Managed switches may contain features which also block multicast messages.)

Then, in the Spotify app, search for devices.

If trivum network inputs are shown there then it is a problem of your WLAN switch, router, or access point.

For example:

- the WLAN router may be configured not to send multicast messages into the WLAN. Check your router configuration.
- the WLAN router may need a firmware update. In rare cases, routers are blocking multicast before the update, and passing through multicast after an update.
- some WLAN access points like Aruba WiFi AP controller have extra options in their configuration to enable bonjour and airplay messages in the network.
- maybe the WLAN router needs to be replaced by a different WLAN access point.
- a network using multiple sub networks like, for example
subnet 192.168.1.x via cable
subnet 192.168.2.x via WLAN
will normally block **all** multicast traffic **by default**, allowing no Spotify Connect, no detection of any trivum device by the trivum iphone app or ServerAdmin tool, and no KNX IP router traffic!
in such cases tell your network administrator to configure
 - full send-through of multicast protocol messages via multicast group 224.0.0.251 port 5353 in both directions:
 - from WLAN to LAN for Bonjour Discovery Requests
 - from LAN to WLAN for Bonjour Discovery Replies
- the network switch itself may block all multicast, especially if it is a large managed switch (with a configuration interface). read more on network switch configuration under [Network failure on group play](#)

Also try a restart of the trivum device (ideally from the web configuration). If the network blocks multicast messages only in one way, this can help at least to show the Spotify Connect inputs temporarily.

Further reading:

[WiFi multicast settings with a Ubiquiti Unify Switch](#)

[SpotifyConnect message analysis with sfk.exe](#)

10. KNX IP Router cannot be found or sends nothing

10.1. Problem

the trivum music server does not receive any KNX messages. A KNX IP router is not shown in the web configuration.

10.2. Solution

- make sure you are using the correct KNX IP router or interface mode.
 - An interface uses TCP communication with only one partner at a time, only through normal LAN IPs like 192.168.1.x.

- A router uses UDP multicast communication, typically via address 224.0.23.12.
- do not use WLAN. if your IP router is connected by WLAN it is very probable that UDP multicast messages (required for all KNX traffic) are not passed through your local network.
- do not use sub networks. for example, if your IP router is located in a network like 192.168.2.x but your trivum system is in a network 192.168.1.x then all kind of multicast messages is blocked, including those via 224.0.23.12.
- connect as direct as possible. connect the IP router to the same network switch as trivum, at least temporary for testing. if there are many network switches between trivum and the IP router some may refuse to pass on UDP multicast messages.
- if you connect both trivum and the KNX IP router directly to a managed network switch or router, it can happen that this one does not pass through UDP multicast messages. And because the KNX IP router name is sent by multicast (on address 224.0.23.12) it is not visible at trivum. You then have to go into your network switch or router configuration and search for Multicast settings. It can help to activate IGMP Snooping with a Querier, or to disable both. See also articles:
https://www.trivum.com/trivum/docs/en/trivum-troubleshooting.html#_knx_ip_router_sends_knx_temporary_and_then_nothing
https://www.trivum.com/trivum/docs/en/trivum-troubleshooting.html#_network_failure_on_group_play Sometimes it may also help to restart the network switch / router, or to update it's firmware.
- compare with the ETS group monitor on your PC or notebook. To do so,
 - deactivate WLAN at the notebook.
 - Connect it by cable to the same network switch as trivum.
 - Configure the ETS group monitor to use IP router mode by multicast.
NOTE: with ETS5 this may no longer be possible, at least not standalone (without IP router hardware). Try ETS4 then.
 - Check if expected messages appear.
- open the trivum web configuration under: KNX / setup KNX communication.
 - Enable "trace bus communication".
 - Show the KNX log. Here you see all incoming messages.
 - Press reload (F5) repeatedly to see the updates.
Compare the KNX log with input shown in the ETS group monitor.
- send a KNX test message directly from the ETS group monitor.
This must always arrive at trivum, if you really connected your notebook by cable to the same switch.
Verify at the trivum KNX log that the test message arrives.
- if the ETS test message arrives
 - press a real KNX button in the wall
 - see if it produces input in the ETS
 - compare with the KNX log at trivum.

- if only ETS shows input, but not trivum, filtering may have to be deactivated at the IP router. sometimes hardware addresses of dummy applications in ETS may be reset unexpectedly, causing a traffic block by filtering.

11. KNX IP Router sends KNX temporary and then nothing

11.1. Problem

After a reboot of the trivum device, KNX IP router is visible and listed at trivum. You can select it. You receive some KNX messages.

But after a while, all traffic stops. The IP router is no longer listed as visible. No more KNX messages are received, until the next reboot of trivum.

11.2. Solution

This can happen with managed network switches. Most probably, on such a switch

- IGMP Snooping is active
- but no IGMP Querier is active.

The sense of **IGMP Snooping** is to reduce multicast traffic: network devices which are not interested in the KNX messages shall not receive it.

But who is interested? That is detected by the **Querier**. Every few minutes, it sends a question "who wants UDP (KNX) multicast traffic?" to all network devices connected to the switch. The devices must reply like "I want traffic for address 224.0.23.12". The network switch remembers that, and continues sending to those who replied.

Summary: if you configure a network switch,

- either activate IGMP Snooping WITH a Querier
- or do not activate IGMP Snooping at all.

See also our extended article on network switch configuration:

https://www.trivum.com/trivum/docs/en/trivum-troubleshooting.html#_network_failure_on_group_play

If that does not solve the problem

then maybe you have too many network switches. For example, if your network looks like

```
KNX IP router <==> Switch1 <==> Switch2 <==> Switch3 <==> trivum
```

then it can happen that multicast and IGMP messages **get lost** on their way from the IP router to trivum. The switches can no longer decide who asked for which traffic, and whom to send it. Change your network to:

```
KNX IP router <==> Switch1 <==> trivum
```

meaning always connect trivum to exactly the same network switch as the IP router.

Note for technical staff: if you are on a linux system, you can listen for active IGMP Queriers by

```
tcpdump igmp
```

if a querier is active you will see something like

```
12:15:10.027907 IP 0.0.0.0 > all-systems.mcast.net: igmp query v3
```

every few minutes.

12. Master/Slave cannot be combined

12.1. Problem:

When trying to integrate slave devices into the master they are invisible at the master, and therefore cannot be selected.

This is normally a multicast network problem.

The slave devices send hello messages by multicast to all devices in the network. However if there are multiple network switches, they may refuse to pass on such hello messages from switch to switch. Even a single switch may sometimes block multicast messages.

12.2. Solution:

First make sure that the slave devices are really in Slave mode. Open a web browser, open deviceip/setup per slave device. Go into: System / Setup / Master/Slave configuration and make sure that the device is set to slave mode.

Make sure that all trivum devices are connected to the same network switch.

Connect all by LAN cable, never by WLAN.

If there is a managed network switch or router, check it's configuration if multicast is allowed, and if multicast is always passed between all network ports.

Also try to restart network switch(es) and/or the router. If it works (temporarily) after that consider

replacing the network switch by a different model, or connect all trivum components to a separate switch instead of connecting them directly to a router.

Also read the following article about multicast configuration,
[No sound on group play with many devices](#)

13. No sound on group play with many devices

13.1. Problem:

You have a master/slave system with **5 or more** trivum devices.

When playing music in a group, it occurs that there is no sound at some devices, either temporarily or permanently.

13.2. Technical background:

This is caused by UDP multicast traffic being blocked by network switches.

Multicast means: one device (with the group play master zone) sends audio packets to the whole network. The target devices which are interested in playing these audio packets listen to that traffic. Multicast may cause highly complex work at the network switches, as they must decide where to send the audio packets to, and where not. It typically fails as soon as multiple network switches are involved.

If you look into the trivum web configuration under

Information / Inspect / Show event log / Print

and you see messages like:

```
192.168.1.100:1204 did not confirm an audio package. (54 4d 05 04)
192.168.1.101:1204 did not confirm an audio package. (54 4d 05 04)
192.168.1.102:1204 did not confirm an audio package. (54 4d 05 04)
```

then this is the confirmation that multicast IP traffic was blocked. In this example, devices with IP 192.168.1.100 ff did not get their multicast packets, and therefore could not play audio.

By default, the trivum system uses multicast audio automatically as soon as 5 or more devices are in a system. With 2 to 4 devices, it sends audio by UDP unicast, which is very reliable, independent from the switch type used. You can check which mode is used in the web configuration under:

- V9: System / Set up / Advanced settings / Use Unicast Audio For Group Play
- V10: Devices / Players / General settings / Use Unicast Audio For Group Play

13.3. Solution:

If you restart all network switches to which trivum devices are connected, it is probable that audio will play again, for the moment. Sometimes it may also help to restart the router.

For a more permanent solution, follow these steps:

- make sure that all trivum devices are **connected to the same network switch**. As soon as they are spread over multiple switches, the switches themselves have to decide what to send to the other switch or not, which is complex and may fail.
- try a **simple unmanaged network switch**, like the TP-Link 1008P, instead of a managed switch. With a simple switch you don't have to configure complex options, and their firmware is very reliable. If you have a master/slave system with up to 7 trivum devices, connect these all to the TP-Link 1008P, then connect a remaining port to the network switch you are currently using.
- you may also use a **group limitation workaround**: in the web configuration,
 1. set the option
V9: System / Set up / Advanced / Use Unicast Audio For Group Play
V10: Devices / Players / General / Use Unicast Audio For Group Play
Always
 2. under Configuration / Zone groups / Add zonegroup
create predefined groups which involve **up to 4 devices** only.
 3. under Configuration / Zone groups / More settings
set: **User can just select predefined groups**

This way you limit the system to **groups playing over a maximum of 4 devices**, with unicast audio only. You may also try to allow 5 devices in a group, this may work or not. 6 devices are normally too much, because in this case a group master zone must send the same audio packet 6 times, causing network queue overflows in the operating system.

If these tips do not help, or you strictly want to connect trivum devices to a large managed switch, continue reading the following article.

14. Network failure on group play

14.1. Problem:

No sound in some zones, slow controls, blocked network during group play with Installer Line products, or during InStreamer play with Multicast option active.

14.2. Solution:

1. Update your trivum system to the latest software.
2. If problems occur while using the trivum InStreamer device then you may disable the Multicast option under: Hardware / Instreamers / Instreamer / Enable InStreamer Multicast. You can then no longer use the same InStreamer directly in multiple zones. But you can still listen to the same

InStreamer in multiple zones by creating a group.

3. If it occurs with group play you may try the Unicast Audio Option, in the web configuration under:

- V9: System / Set up / Advanced / Use Unicast Audio For Group Play
- V10: Devices / Players / General / Use Unicast Audio For Group Play

With this option, audio data in group play is no longer sent by multicast, but by UDP unicast, which should work with every network switch. This works only if not too many trivium devices are part of a group, as it creates a higher load at the master zone that sends the data. It should work safely with 4 devices, for example 4x SC344. It may still work with more devices, so you can just try the option and see if group playback still sounds stable. But, for example, with 10x AudioBox or 10x RP310 systems this option will no longer work. Here you will have to use Multicast and apply Switch configurations as described under 4. below.

- Use an IGMP capable network switch.

At the switch, make sure that IGMP snooping is really used (via the switches configuration surface), including an active "Querier" (possibly Switch dependent).

The group audio play produces a high network traffic. The IGMP protocol makes sure that this traffic reaches only those devices interested in that traffic. But for this the switch needs to understand IGMP, and the trivium device requires the software version listed above.

Switches supporting IGMP are, for example, HP 1920G, HP-E2620-24-PoEP, Cisco SG300-10.

Furthermore, if the system is controlled by iPads, an Apple Airport Express WLAN access point is recommended.

Example configuration with HP 1920G switch:

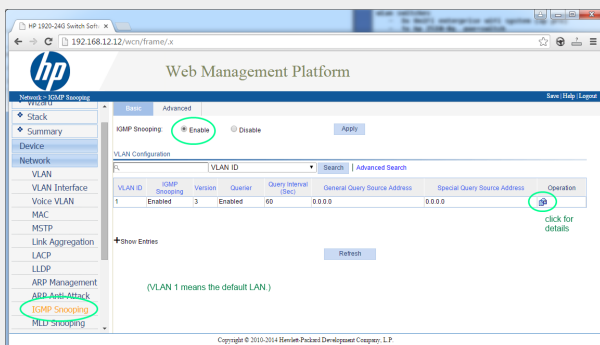

Figure 1. Screenshot Enabling IGMP Snooping. (use right mouse button, then Open Image)

First enable IGMP globally. But then you must also click below Operation and set:

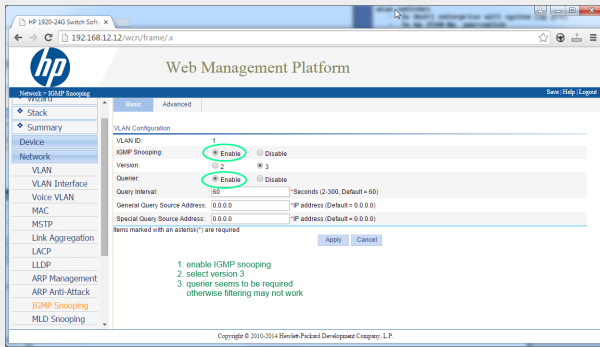

Figure 2. Screenshot Enabling IGMP Snooping and Querier

Enable: IGMP, version 3, with Querier.

Then select "Save" at the right top to store all settings permanently.

If you think there may be a network loop in your cabling, also enable: MSTP/Global/Enable STP Globally/Enable

14.3. Possible problems of network topology at the customer:

If multiple switches are used then care must be taken that either all support IGMP, or that the one supporting IGMP is placed at the top, containing all trivium devices.

So the network should look like, for example:

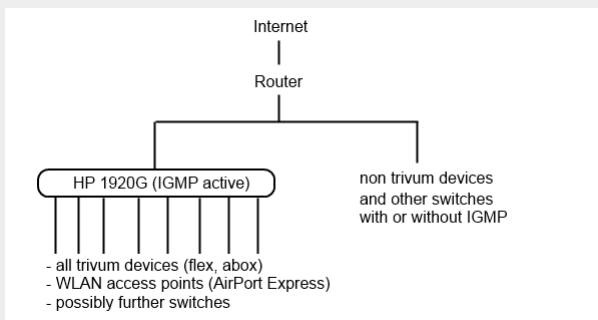

Figure 3. Topology

To avoid flooding of non trivium devices by unwanted audio messages.

14.4. Configuration of further switches:

With a HP-E2620-24 switch there is only an option "IGMP" by default, without details. It seems that no extra global save option is required. It seems that this switch uses Querier by default. With our tests the IGMP filtering worked immediately. You may also configure details, but for that you need to connect by RS232 cable to that switch. When restarting the switch, to get again to the switch config, you may have to enter it's IP without any path behind. Same as with 1920G, in case there are still network problems you may enable: Spanning Tree/Tree Management/STP

At a Cisco SG300-28 switch select:

Multicast

Properties/Bridge Multicast Filter: Enable

IGMP snooping/Status: Enable

IGMP Table: Edit

IGMP Snooping Status: Enable

IGMP Querier Status: Enable

IGMP Querier Version: IGMPV3

After setting these values, wait 2-3 Minutes before filtering becomes active. Select the blinking "save" button at the top then select: source/running config, destination/startup.

The Cisco also supports STP in case of network loops.

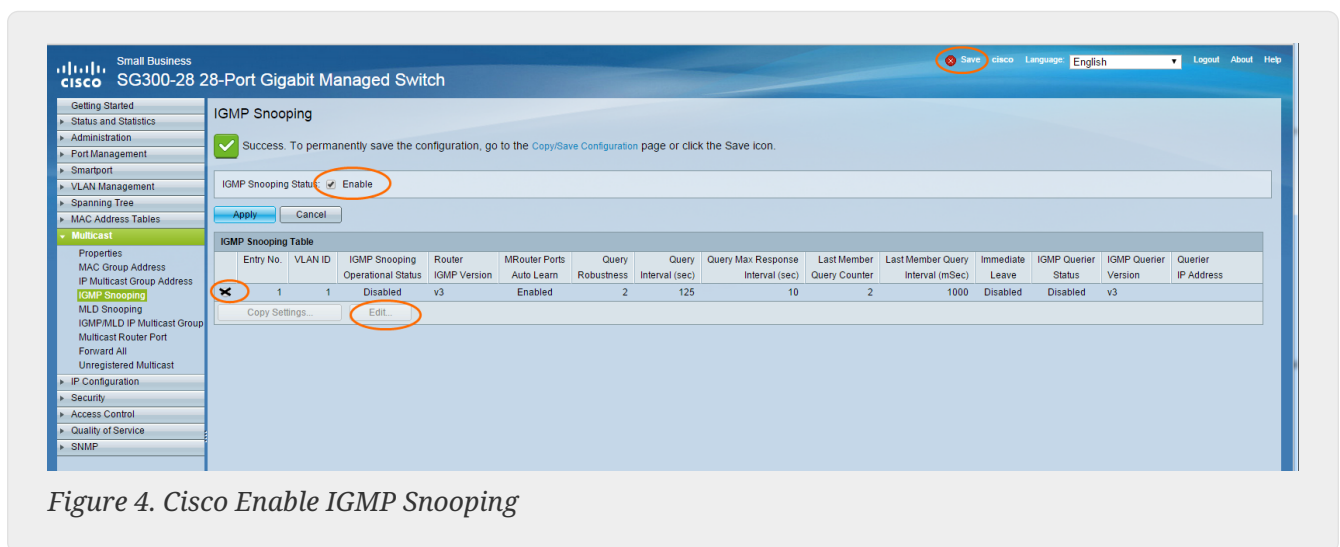
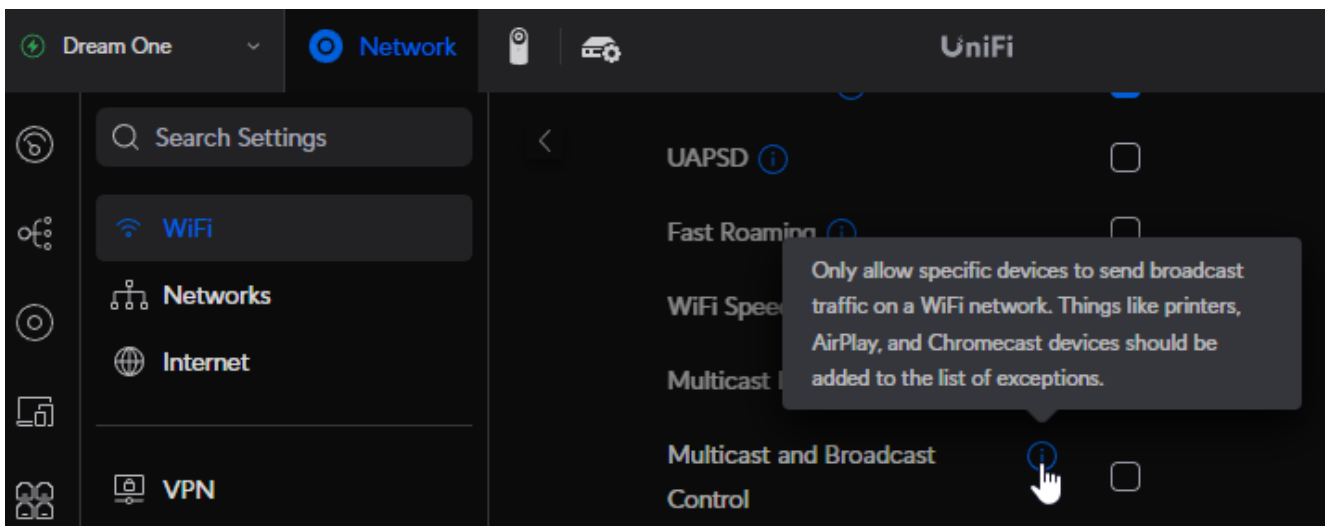

Figure 4. Cisco Enable IGMP Snooping

15. WiFi multicast settings with a Ubiquiti Unify Switch

In the management page of a Unify Dream One / UDM Pro Switch, the following settings are most relevant for the (non) visibility of AirPlay inputs, Spotify Connect inputs, and discovery of trivium devices by the trivium App:

- Settings / WiFi / (select network) / Advanced (Manual) / Multicast Extension
- Settings / WiFi / (select network) / Advanced (Manual) / Multicast and Broadcast Control



If "Multicast Extension" is set, disable it. The intention is to convert Multicast traffic to unicast, which is not supported by trivum devices.

If "Multicast and Broadcast Control" is set, disable it for a test. If it is required in your network to have it set, extend the setting, by adding trivum device MAC Addresses to the list of exceptions.

After such a change, you may have to do a quick restart of the trivum device, or enable "send zone names every minute" in it's AirPlay settings, before you can see it's AirPlay inputs on the mobile.

There are also other settings which are inactive by default. If they are set, carefully read their (i) info text, as they may block device visibility as well.

- Settings / Networks / Global Network Settings / IGMP Snooping

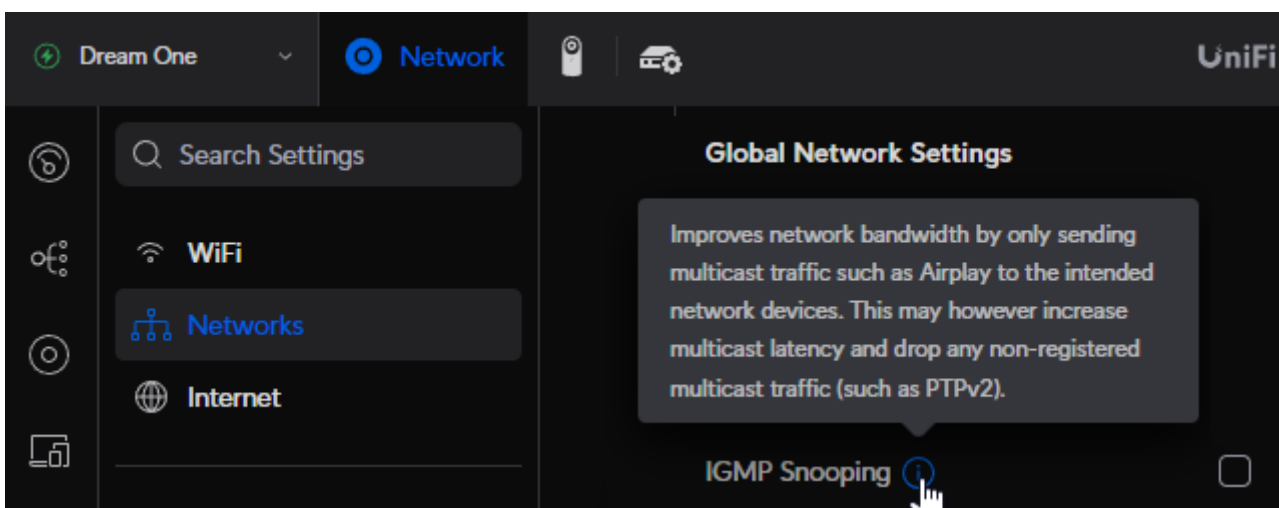

If this is set, disable it for a test. If your network experiences overloads, e.g. during group play over many devices, enable it.

- Settings / Networks / (select a network) / Advanced (Manual) / Isolation

This should not be set, otherwise devices cannot see each other.

15.1. traffic across different subnets (VLAN's)

In your Unifi switch, go to "Settings / Networks" to get a list of your VLAN's, for example:

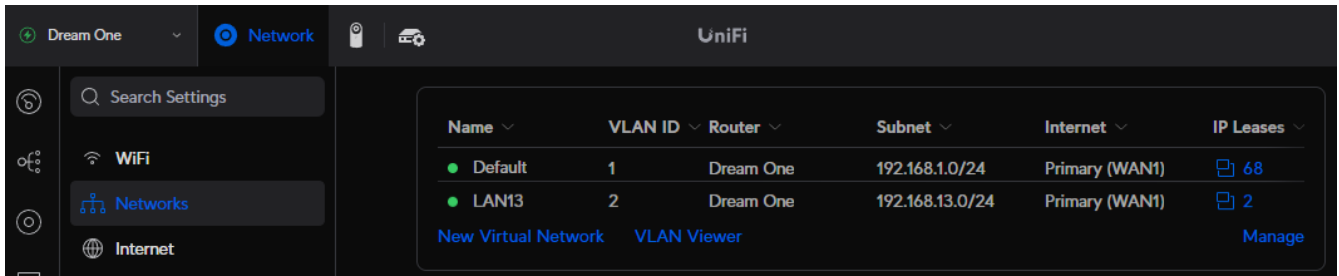

The screenshot shows the UniFi Network settings page. On the left, there is a sidebar with navigation options: Search Settings, WiFi, Networks (selected), and Internet. The main content area displays a table of VLANs:

Name	VLAN ID	Router	Subnet	Internet	IP Leases
Default	1	Dream One	192.168.1.0/24	Primary (WAN1)	68
LAN13	2	Dream One	192.168.13.0/24	Primary (WAN1)	2

Below the table, there are links for "New Virtual Network" and "VLAN Viewer". A "Manage" link is located at the bottom right of the table.

If there is more than one entry, the network is divided into different segments, or VLAN's.

By default, **any multicast traffic between VLAN's is blocked.**

So in this example, trivum devices with IP 192.168.13.x cannot be seen on devices with IP 192.168.1.x, and vice versa.

A mobile phone or iPad in network 192.168.1.x will not list any AirPlay input or SpotifyConnect input of a trivum SC344m or RP341v2 in 192.168.13.x, and the trivum App running on the mobile will also not show these trivum devices.

A KNX IP router in one VLAN cannot be seen by a trivum device in a different one.

In theory, rules can be added to pass multicast traffic between different VLAN's. But this is beyond this document, and requires a network administrator with detailed knowledge.

16. WLAN Errors while streaming Audio with trivum devices

16.1. Problem

trivum may use multicast messages to send audio from a master AudioActuator synchronized to it's slaves. Depending on the switch used in your network, it may or may not be able to filter multicast traffic.

16.2. Solution

Make sure to use a switch that supports an option Enable IGMP Snooping. With this option, the multicast messages are sent ONLY to devices that subscribed to this kind of traffic, but NOT to the whole network, like the WLAN. Read all details about switch configuration here: [No sound on group play with many devices](#)

17. AirPlay sound dropouts

17.1. Problem

AirPlay sound dropouts, which are primarily caused by WLAN reception problems.

17.2. Solution

1. Compare AirPlay via WLAN vs. LAN cable.
2. Install iTunes on PC or Mac
3. Make sure the PC/Mac is connected to network only by LAN cable, but not (also) by WLAN
4. Select trivum as AirPlay output in iTunes
(at the top of iTunes, right near the volume slider)
5. Play an .mp3 music file

→ If music plays well from iTunes via LAN cable, but not from an AirPlay device via WLAN, the problems are caused by bad WLAN reception.

Furthermore, check direct play of music files at trivum. If sound is interrupted with direct music file play, then the problem is not AirPlay related.

18. Further issues (not UDP multicast related)

19. FM radio reception disabled by cable provider

Some German cable providers removed FM radio distribution from their cable network.

In this case you have these alternatives:

- receive FM radio over the air, with an antenna as shown in the following article.
- receive DAB+ radio over the air, with an antenna as shown in the following article.
- buy a DVB-C radio tuner, for example:
<https://www.amazon.de/Vistron-VT855-Kabelradio-Kabelfernsehen-Telecolumbus/dp/B078J9MNKP/>
and connect this to a line input of your trivum device.
- use TuneIn Web Radio.

20. DAB no audio reception

DAB may find many stations, but no audio is playing.

If you have a household with cable TV and radio, please note that in most cable networks you may only receive FM radio, but no DAB+. This is due to incompatibility of frequency ranges of DAB with other services, like internet.

In many cases DAB can be **received via air only**.

If you use a simple 20 cm wire directly at the trivum device, this may work with devices like RP341v2, RP311v2, RP321 as long as your switch cabinet is not in the basement.

With an SC344m it will no longer work if you have all 4 zones playing, due to interference of the amplifiers electronics with the wire directly near the device. DAB+ works with low signal power and is very sensitive to interference, opposed to FM reception.

To solve this,

- get a 2m or longer shielded antenna cable, and suitable adapters. connect that to the SC344m antenna connector.
- at the other side of the cable, several meters away from the SC344m, connect your simple wire, or a throw antenna. This should be sufficient at living room level or higher.

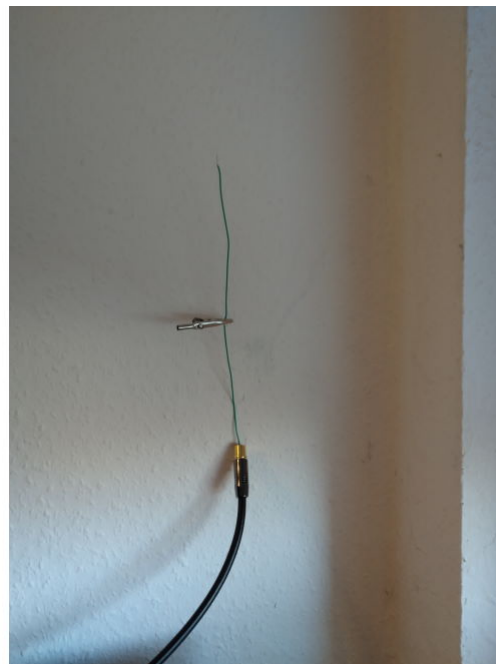

- if your SC344m is located in a basement, you will have to connect the SC344m to an external antenna, or take a long antenna cable up to higher levels in your house, where you connect a wire or throw antenna.

21. Cannot find option to hide default Stream, Tuner or LineIn actions

Since software 9.72 these settings were moved in the web configuration.

With Software V9, look under:

configuration / actions / define which standard sources should be available

With Software V10, look under:

customize the system / actions / general settings

Hiding of default LineIn is configured per zone under:

V9: configuration / zones / zone / basic settings / default sources

V10: customize / zones / zone / define the default sources

22. Search is not possible in WebUI

When trying to search in the NAS library or TuneIn, no keyboard appears.

Update to software V9.73 build 16282 or higher, then do a long touch on the three stripes button at the right top, to reload all content.

You may also have to do a long touch in the search field itself. In the NAS library search, make sure not to touch into the text "Any pattern". Touch only into the empty field right to that.

23. Spotify plays in zones unexpectedly

Problem: zones are switches on unexpectedly by Spotify Connect.

23.1. Possible reasons

- 1) you allowed a guest to stream Spotify to your trivum system, and after the guest leaves your house, he presses Play on the Spotify app, not knowing that this activates play in your house via internet
- 2) you gave a family member your Spotify account data, who is out of house, but he selects Play, not knowing that this activates play in your house via internet
- 3) anywhere in your house is a device (tablet etc.) with Spotify app and your account data logged in, and for some reason play is activated from that

23.2. Solution 1: restrict playback start to specific accounts

For case 1), go into the trivum setup under: Info / Inspect / Eventlog.

There you should find a clear info at which time what Spotify user played on your system:

```
12.6 / 21:28:31 SPOT: 1334.2 StartSpotCon - Zone Living Room - user ewfihehwfu3hr3e
```

If that is not your own user, go to:

```
Music / Streaming / Spotify Connect
```

then select "limit spotifyconnect play to selected user names", and follow the instructions shown. This way, only your own Spotify user is allowed to play on the trivum system.

For case 2) and 3), if you are unable to find out who is using your account

- login on spotify.com with your user
- under "account", change your password
- under "account", select: Sign out everywhere

Then go into the Spotify app on your mobile. Log in again with the new password. Connect again to the trivum system. You will be the only one who can do that now.

Please note: if you stored SpotifyConnect Preset favorites on your trivum device, it is not sure if you can still use them after a password change. Maybe you have to re-create them.

23.3. Solution 2: disable zone activation on playback start

Another solution is to disable zone activation through Spotify Connect.

In the V9 Multiroom Setup, go to:

```
configuration / zones / zone / basic settings / control zone selection
```

then select: **Zone to activate on network input: No zone control.**

With software V10, go to:

```
customize / zones / zone / default sources
```

and select the gear icon at the streamer, to change the streamer settings. There you find **Configure the streamer's SpotifyConnect settings**. Therein, select "Show Spotify Connect listener". Setting this option will automatically disable "Show SpotifyConnect speaker 'Zonename'".

This way, the SpotifyConnect input is no longer linked to a zone, and cannot switch it on.

2) create a global action to play Spotify manually:

In the V9 Multiroom Setup, go to:

configuration / actions / define actions which are always available

In the V10 Multiroom Setup, go to:

customize / actions / define actions which are always available

Then create an action:

activate a source / streaming (using zone default streamer) / Spotify Connect

Playing Spotify is then done in two steps:

1) In the Spotify app on your mobile phone, select the trivum network input, which now may have a different name, and start playing. Nothing audible will happen at trivum, as the zone is not switched on.

2) Go into the trivum app, into the target zone, and select the "Spotify Connect" action. Now you will hear the sound.

24. Bluetooth cannot be paired/played with AudioBox P150

- make sure you have software V9.72 build 16033 or higher.
- enable WLAN on the AudioBox P150:
in the web configuration, go to **setup / network (WLAN)** and select "enable".
It is **not** required to scan networks and connect to a real WLAN network. Just activate the "enable" switch.
If your AudioBox is a slave in a master/slave configuration, you must enable WLAN by going to the web configuration of the AudioBox device under **audioboxip/setup**

25. RP341v2 permanent blue light

This shows that the power supply voltage is too low, probably below 18 V.

Check connection cables to the power supply. Check the power supply itself, measure it's output voltage. Check if you have other power consumers connected to the same power supply which may consume too much energy, or if there are other consumer devices at the same power strip, which are used only from time to time. If in doubt, replace the whole power supply, or connect it to a different socket.

26. RP311v2 RP321 RP341v2 actuators are blinking purple/violet

This is an overvoltage error, so disconnect the devices immediately from the power supply! Speaker outputs are shut down for safety, so you cannot hear sound.

The RP devices should be used with a 24 V power supply, for example Mean Well HDR-100-24.

They should NOT be used with, for example MeanWell KNX 20E-640 as such power supplies provide 30 V, which is too much.

27. RP341v2 Fuse channel 2+4 broken (code 2000)

There are two power connectors with +/- each. Code 2000 occurs if the right connector gets less than 13 V of voltage, or if there is no power at all at the right connector. The LED should blink blue in this case. As soon as more than 13 V is connected, the error should be reset automatically (with software 9.73 / firmware 1.26), and the LED should appear green again.

28. RP341v2 no sound on all outputs

This happens if you connect a power supply with too high voltage.

For example, a Meanwell power supply has an adjusting screw for voltage regulation. If this happens to be set to 28 V, that is too much, and there will be no sound. Make sure it is adjusted to exactly 24 V only.

29. RP341v2 no sound on outputs 1 and 2

This happens if you connect a **single power supply unit** only to the **first power input**. There will be sound on outputs 3 and 4, but not on 1 and 2.

Please follow these steps with your new device:

- if you want to use just one power supply, connect it to the first power input, then also connect a bridge wire from plus of the first power input to plus of the second power input. Start the device **after** doing this bridging. Connecting the bridge live while the device is already powered on will still produce no sound.

- if you have two power supplies, connect both to power inputs 1 and 2. Then power-on the device.

30. RP3xx channel overload

Make sure that you have at least software V9.78 (or 10.03) build 17126 or higher installed. Build 17126 contains important fixes for RP devices when handling high sound volume.

If you have the latest software, but the alert still appears, this can be caused by the following reasons:

1) There might be a temporary voltage overload at the output, especially a short circuit at the speaker cables, e.g.

- by a short thin wire that connects accidentally.
- by defect speaker cables.

Disconnect the speaker cable from trivum, then measure the resistance. normal are 5-8 Ohm. if there is only 0,5 to 1 Ohm then they are defect.

Note: even with a short circuit there is normal sound. You may only get an error as soon as the volume is increased.

2) If you turn the volume very high with speakers **disconnected**, the amplifier chip cannot measure the output load correctly, and produces an overload alert in error. Please do your tests only with **connected** speakers.

3) If you use very high speaker volume combined with unusual environmental conditions, like high air temperature and bad ventilation of the switch cabinet.

Check the device temperature: in the setup (trivumip/setup), go to [information / about](#).

Normally the temperature is below 80 degrees celsius.

4) By extreme sound settings: If you selected bass or treble enhancements, or a DSP preset, reset all to default before doing further tests.

To be on the safe side, e.g. on changing environmental conditions, you can limit the zone maximum volume to 90% in the setup.

If you checked all these points, but "channel overload" still appears with connected 8 Ohm speakers, contact trivum support.

31. RP310 no sound

This can happen if the supply voltage is too high. Carefully check that it has only 24 V. Using a too high voltage may damage the outputs, so even after reducing to 24 V, there may still be no sound.

32. RP311v2 no DAB audio due to swapped antenna wires

The very first RP311v2 devices delivered in Jan-2022 have a sticker showing the radio GND and Signal connectors in wrong order (swapped). That means if you connect the antenna as shown on the sticker, it may find DAB stations, but there is no sound. (FM may still work)

Here is the full list how to correctly connect the antenna with different devices:

Current devices:

- RP311v2: Antenna Signal is nearest to Ethernet. Antenna GND is nearest to outer edge of casing.
- RP321: Antenna Signal is nearest to Ethernet. Antenna GND is nearest to "Output 2 Left -".
- RP341v2: Antenna Signal is nearest to "Output 3 Left -". Antenna GND is nearest to Ethernet.

Older devices:

- RP311v1 (until 2021, just FM):
Antenna Signal is nearest to "Control Out". Antenna GND is nearest to "Power 24V +".
- RP341v1 (until 2021, just FM):
Antenna Signal is nearest to "Line In Sym". Antenna GND is nearest to "Line In Left (wire)".

33. If TIDAL account setup does not complete

If you try to configure a TIDAL account, but it does not complete, with an endless info "No reply yet", check your network configuration. We have seen one case where static IP was configured with the google nameserver 8.8.8.8. Apparently that name server provided other tidal server addresses then usual, causing a failure of the account setup. The solution was to switch the device to DHCP, at least for the time of account configuration.

34. If TIDAL does not play

If you have a TIDAL Premium account, disable "Use high quality streaming" in the trivum-Setup. High quality streaming requires a TIDAL Hifi account.

35. Divus KiBro App does not work

Please no longer use this app, it no longer allows connections to non-Divus devices. Use instead the

[trivum Control App for Android](#)

36. No TuneIn Menu, Error 403 in TuneIn plugin

If you have older Software V8.x installed you must update to version 8.78, to fix a bug in the TuneIn plugin.

If you have the latest V8 or V9 software already, your system may have been locked out temporarily from TuneIn by it's internet IP address. This can be caused by too many web radio requests per day. You can verify this by typing in your web browser:

```
opml.radiotime.com/Browse.ashx
```

If this also produces a 403 error then you have to wait for one day until the blocking is lifted. Alternatively, change your internet IP address, by disconnecting and then reconnecting the internet (in your router). If your IP does not change although you disconnected the internet then contact your internet service provider for help on that.

37. No access to TuneIn favorites

On 12.09.18 there was a change in the TuneIn API which caused blocking of TuneIn favourites by a 403 Error.

If you update to V9.37 (or V8.79 with touchpad 2.15.13617) it will be possible to use favourites again, but please note:

- old device based favourites are lost. but you can create new ones.
- TuneIn account linking is possible, but if you don't see your favourites, you have to go into the web configuration, under Streaming / TuneIn, and select again: 'Link this device with account'

38. TuneIn stations do not play with V8 software

One possible reason is that more and more TuneIn stations switch to encrypted transfer by SSL. Playing such stations requires software V9, so you may have to consider a V9 update.

<https://www.trivum.com/trivum/docs/en/trivum-update.html>

39. V8 and V9 devices are not compatible.

If you have several trivum music server devices and want to combine them as master/slave then all must be either V8 or V9. If you have a trivum music server with TouchPads, then either all must have V8 software (server version V8.x and Touchpads V2.13) or all must have V9 software (meaning server version V9.x and Touchpads >= V2.40)

40. InStreamer: if Digital Input has no sound:

If you get sound by analogue input, but not by digital, perform these checks:

- check the cable if it shows a light.
- disable Dolby Digital mode at the audio source, if active. The InStreamer has no Dolby decoder and produces no sound if Dolby is used.
- compare with a different device that accepts digital input. is sound audible with another device?
- make sure the InStreamer Firmware is up to date (V1.26 or higher)
- double check that analogue sound is still audible when disconnecting the digital cable (which has priority over analogue once connected). make sure that the sound source delivers sound permanently.
- disconnect the device from power, then reconnect. Old InStreamer devices (delivered around 2015) may fail to provide sound if there was no input for several days, and then need a cold restart.

41. InStreamer: if Digital Input is distorted:

Update the InStreamer to Firmware V1.07 or higher, available with Build 11532 of the latest V8 or V9 server software.

Check the InStreamer's Level-adjust setting in the web configuration. Keep it below 100 percent, or try lower values, like 75 or 50.

If you connected a CD player, note that:

- the InStreamer's analogue input expects a signal strength of 2.1 Volts RMS.
- some CD players provide 3 or 4 Volts RMS, which is too much.
in case of 3 volts, some correction can be done by reducing the level-adjust.
- some CD players provide a special output for surround receivers, with a far too high voltage of 7 Volts RMS. Do not connect to such an output.

42. InStreamer Update Fails

If you select to update InStreamer at the trivum server, but after a while it still has the same version, this can be caused by active IGMP at the network switch. Normally IGMP is a good and necessary thing to protect the network during group audio playback. But during InStreamer update, the InStreamer runs in a very limited system mode, unable to send correct IGMP announcement messages. This may cause the switch to block important data being sent to the InStreamer.

42.1. How to check:

- with V9 build 11577, look into: Inspect / Show recent update log.
- with V8 build 11577, type in the browser address bar: trivumip/print/messages

If you see a message "device does not react" then the update data was blocked.

42.2. How to fix:

- connect both trivum server and instreamer to the same switch
- deactivate IGMP temporarily at that Switch
- retry the update
- once completed, reactivate IGMP.

43. Distorted, cracking or interrupted sounds

43.1. Reason

The sound disturbances could be clippings caused by one of the following:

- an active DSP setting. if you have a DSP preset in use, test using "Flat / default" for a comparison. If you want to keep using the DSP, you may have to set "adjust volume" in the audio output settings to a value lower than 100.

If you create a DSP preset yourself, it is a good idea not to boost frequencies by Amounts > 0, but to reduce those frequencies that you do not want to hear by negative amounts.

If any warnings are shown in red, strictly follow the instructions. For example, EQ with +db and BassEnhance should not be used in combination, as the latter one already lifts the sound volume.

- active Treble adjust, Bass adjust, or Bass enhance level. try setting those values to 0, or set "adjust volume" of the audio output to a value lower than 100.

44. The sound is interrupted every few seconds

44.1. Reason

It could be system overloads by excessive tracing.

44.2. Solution

In the trivum Setup, go to: System / Setup / Advanced.

If the field contains `traceplayer=9` then this will internally produce massive trace output, leading to interrupted sound.

Simply clear the field.

45. StreamSource card hangs until restart with no audio

45.1. Problem

Some StreamSource cards delivered in 2014 show the following behavior: * First, everything seems OK, it plays audio. * After a random time, sometimes seconds, sometimes hours the card stops to play audio but no error message is shown anywhere. * The green "C" LED at the card goes off. * Furthermore in the cardlist the card may show a red message Slave inactive.

When trying to use the card an error CardHost inaktiv may appear.

After a full restart of the trivum system, it should work again, until the next error. The reason for this is a change in specifications of a chip on the card, causing incompatibility with V1.30 firmware. You may identify those cards by looking on the big square chip "LPC2365". In the lowest line, if you see "NSD1317D", with a "D" at the end, then the error may occur (with the older "NSD1317B" revision it should not occur). Even if the number is not 1317 but different, errors may occur - relevant is the "D" at the end.

45.2. Solution

1. Update toolkit

If you received a card update toolkit, you can fix this yourself by flashing the card with the latest V1.31 Firmware:

2. Read the toolkit documentation

3. Look as well the toolkit screenshot

4. Follow all instructions.

5. Use the **latest** firmware file **StreamSource-1.31.hex** available from support



Do NOT use the contained `StreamSource-1.30.hex` file

45.3. Repair service

Or you may send us the card back for repair.

46. No sound from some StreamSource cards

46.1. Problem

When using 3 cardhosts with many StreamSource cards (STS) and PowerAmpConnect cards (PAC) be aware of the following restrictions:

- STS (or any source card like RDSTunerSource) must be placed within slots 1-8 of a cardhost only
- PAC can be placed in any slot, but normally they are placed in the higher slots, as the lower ones are used by sources
- sound produced by STS in slots 1-8 of the first cardhost can be played on any PAC in any cardhost
- sound produced by STS in slots 1-8 of the second cardhost can only be played on local PAC within the second cardhost.
Same applies for third or even further cardhosts: sound can only be linked locally within the cardhost.

This means, for example, that sound from STS in slot 1 of 2nd cardhost can NOT be played on a PAC in the first cardhost.

On a C4 system with 2 cardhosts, these restrictions do not exist, so sound from a STS in the 2nd cardhost can be played on a PAC in the first.

47. Short Sounds may not play correctly

47.1. Problem

If you try to play short music files with less than 15 seconds, it may happen that only a few seconds or even less is played and then the track is repeated or skipped. This also depends on the sample rate used (22 kHz versus 44 kHz).

47.2. Solution

To achieve correct playback, you may

- Create a longer music file that contains the same sound many times

OR

- Extend your music file by up to 15 secondes silence



You can use the free audio editor Audacity. (<http://audacityteam.org/>)

48. AudioBox P150 sound dropout every 2 seconds

48.1. Problem

In the second zone of a slave device, sound drops out every 2 seconds.

48.2. Solution

Check the configuration for redundant output mappings. For example, if both the first and second zone of the device use the same Cinch output, it causes a conflict.

49. Digital Line Input / TOS Link no sound or just noise

49.1. Problem

A source like TV is connected by optical TOS link cable to a trivum device like the AudioBox P150, but only noise is audible.

49.2. Solution

Disable Dolby Surround at your source. The trivum device can only process plain PCM input via TOS link, but no dolby data.

49.3. Problem

A source like TV is connected by optical TOS link cable to a trivum device but nothing is audible.

49.4. Solution

The adapter or digital connection may need to be reset.

It could be sufficient to disconnect the adapter from the trivum device, wait a moment, then reconnect it. If that does not help,

- Disconnect the trivum device from power. Disconnect the TOS Link cable. Switch off the source (TV etc.) for the TOS Link.
- Reconnect the trivum device to power. Wait until it has fully started. Then reconnect the TOS Link cable. Then switch on the TV.

50. RP341/RP340 power connection how to

The RP34x can be used with one or two power supplies. For details read the following article.

51. 4 Zone Actuator, RP341/RP340 no sound in zones 3 and 4

51.1. Problem

No sound in zones 3 and 4 by using a RP341 or RP340.

51.2. Solutions

51.2.1. Insufficient power supply.

There might be an insufficient power supply. The RP341/RP340 needs

- 2x 3.83 A (or more) power supplies or
- 1x 7.66 A (or more) power supply

Check that the power supply/supplies is/are connected correctly

- 2x 3.83 A power supplies:
 - connect one power supply to the left "24V DC (+) (-)" field
 - connect one power supply to the right "24V DC (+) (-)" field
- 1x 7.66 A power supply:
 - connect the + cable to both "24V DC (+)" screws
 - connect the - cable to both "24V DC (-)" screws
 - Check the cable for damages
 - Check the functionality of the speakers



If you have two power supplies, swap them.

If the system fails to start, or after startup outputs 1+2 produce no sound, the power supply is faulty.

51.2.2. Defective Fuse

In rare cases a defective fuse may be the cause of the fault. Normally this should show an error in the web configuration.

52. RP311v1 Fuse 1 broken error

52.1. Solutions

If you do a software update to the latest V9 or V10 software, but the error still remains, the fuse may really be broken.

open one cover part of the casing. the fuse directly at the power connector is the relevant one.

[RP311v1 power supply fuse] | [../docs/images/rp311v1-fuse.jpg](#)

It's a Siba 158000.2,5 oder Littlefuse 045202.5MRL.

RP341v1 uses fuse models with different power:

Littlefuse 0452005.MRL (5A), or Siba 158000.5

53. Spotify Connect Inputs are not visible with group play

Please find articles on that in the FAQ:

https://www.trivum.com/trivum/docs/en/trivum-faq.html#_spotify_connect_inputs_are_not_visible_with_group_play

https://www.trivum.com/trivum/docs/en/trivum-faq.html#_airplay_inputs_in_brackets_cannot_be_used

54. AirPlay cannot be used from a Desktop Mac or PC

54.1. Problem

XMBC may cause incompatibilities.

54.2. Solution

Check if AirPlay is working with any AirPlay device, for example AppleTV.

If not:

- Check if XMBC is installed on your system.
- Check if XMBC has AirPlay support active. (This may cause incompatibilities.)
- If so, uninstall XMBC and retry.

55. Unexpected Zone On with unexpected music play

55.1. Problem

Zone switches on and plays unexpectedly

55.2. Solution

Look carefully which source is active, and what is played.

You may also look into the system's Eventlog, in the web configuration under: Information / About / Show Event Log.

There it tells clearly what event caused switch on of what zone.

Possible activation reasons:

- SpotifyConnect: if you had a guest in the days before and allowed them to play SpotifyConnect on your trivum system then it may play unexpectedly anytime later, even if your guest is out of the house, far away. This is a design issue of the SpotifyConnect network, which cannot be changed.

You may protect against this by the following option:

Music / Streaming / SpotifyConnect / Limit SpotifyConnect play to selected user names.

- Play may be caused by a misconfigured alarm. Look which zone is active, and check it's alarm settings.
- Play may be caused by a KNX automation event, or by a HTTP API request.
- If the Eventlog tells HTTP as the event source, look at the IP address part given. For example, "HTTP .222 GET" normally tells that IP 192.168.1.222 sent a request, if your network is 192.168.1.x. Look into the list of control units. Identify the origin, like a Touchpad or Tablet.

56. SpotifyConnect changes volume on next track

56.1. Problem

SpotifyConnect play starts, then at trivum the volume is changed.

As soon as the track end is reached, and the next track starts, the volume jumps back to the volume used before at the tablet.

56.2. Solution

Check your SC device configuration if multiple zones use the same Streamer:

- Configuration / Zones / zone / Basic settings
- look at: Default streamer

normally Zone 1 has Streamer 1, Zone2 has Streamer 2, and so on.

If, for example, Zone 2 also uses Streamer 1, then the system refuses to send volume changes in a zone to SpotifyConnect as it is ambiguous.

Reconfigure the system to use one streamer per zone exclusively.

57. SpotifyConnect switches zone on unexpectedly

57.1. Problem

A guest or family member X plays SpotifyConnect from his mobile to your trivium device. Then he leaves the house.

Suddenly a zone switches on and plays SpotifyConnect again. This is caused because X forgot to unselect the trivium device in his Spotify mobile app.

57.2. Solution

To protect against unwanted play, reconfigure the system from instant play to two-step play:

- in the web configuration, go into each zone under

configuration / zones / zone / basic settings

- look at the bottom for "control zone selection for Spotify Connect", and change "Zone to activate on network input" to "No zone control".

From now, selecting a trivium input in the Spotify app will no longer play music in a zone automatically.

- create a global action under

configuration / actions / define actions always available

add new action / activate a source / streaming / Spotify Connect

this causes an action "SpotifyConnect" being shown in every zone.

To play Spotify music now, the user needs two steps:

1. select a trivum network input in the Spotify app, and start playback.
Nothing will happen at trivum so far, nothing is audible.
2. then go into the trivum app, and touch the "SpotifyConnect" action.
this will start playback of the incoming music.

If the SpotifyConnect network input is shown as "Input 1" instead of a zone name, go into the first zone, then touch SpotifyConnect there. If the system has a default setup, "Input 2" will map to the 2nd zone, and so on.

58. SpotifyConnect volume goes up unexpectedly

58.1. Problem

You want to change the volume in the trivum user interface just a bit, but it goes up by itself unexpectedly.

58.2. Solution 1

This could be a rare case of special configurations. Go into the web configuration under

Music / Streaming / Spotify Connect

and carefully check which control zones are set for which device. The control zone controls volume. With some devices like RP341v1 you have to assign a single zone of that device as control zone. Then make sure that - in a group, no other zone of that device becomes the master zone - you select that zone in your Spotify client, and no zone with a name in () brackets.

58.3. Solution 2

Someone else may have used Spotify with an account that is still active in your music system. For more on that, read "Unexpected Zone On with unexpected music play" further above.

59. SpotifyConnect shows only one input with SC

59.1. Problem

Normally an SC device provides 4 SpotifyConnect inputs to the network, but only one can be seen.

59.2. Solution

Check your SC device configuration if multiple zones use the same Streamer.

- Configuration / Zones / zone / Basic settings
- look at: Default streamer

If, for example, all zones use Streamer 1 (which makes no sense in most cases) then there will be only one SpotifyConnect input.

Reconfigure the system to use one streamer per zone exclusively.

60. Cannot update / no internet or nameserver

60.1. Problem

The trivum device needs configuration data from a DHCP server. A DHCP server gives the device an IP address, and it tells about which Name Server to use. A Name Server is required to connect to the internet for

- web radio playback
- software updates
- NTP automatic time setting.

60.2. Solution

Therefore make sure that your Router/Switch/Modem that connects your local network to the internet provides a DHCP service which also gives correct Name server information.

Follow these steps:

1. Open your Router's web configuration GUI in a web browser
2. Search for settings like: DHCP and Name Server
3. Make sure that DHCP is active
4. Make sure that Name Server information is sent into your network.
If you see some Nameserver address like n.n.n.n then verify that this server actually exists.
On the commandline with a command like
`ping n.n.n.n`
And if you have no idea what Name Server IP address to use for configuration, try 8.8.8.8 (Google Nameserver)
5. After changes to the network configuration, first check with a PC or Notebook if Internet access is still working, by opening some internet website.
6. Then restart the trivum device.

61. Bad sound with stereo speaker

61.1. Problem

A stereo speaker produces damped or massively reduced sound. If you adjust balance to -15 or +15, to hear only left or right, it sounds normal.

61.2. Solution

Check the polarity of the speaker connection, if + and - are connected correctly both for the left and right channel.

If, for example, the left channel is correct but the right channel has + and - swapped it must cause bad sound, as audio waves from left and right will wipe out each other.

62. Bad sound when standing between two speakers

62.1. Problem

Sound is normal as long as you are near one speaker, but standing in a room between two speakers the sound seems to get wiped out.

62.2. Solution

Check the polarity of both speaker connections, if + and - are connected in the same way for both speakers.

If, for example, speaker 1 is connected correctly, but speaker 2 has + and - swapped, it must cause bad sound as audio waves from speaker 1 and 2 will wipe out each other.

63. How to configure the speaker db switch

trivum speakers have a small switch with 0db / -3db written on.

this is an option for height reduction. if you listen to a pink noise signal, you will hear that the 0db setting (default) sounds clear, while the -3db setting is a little damped in the heights.

normally you should keep this switch on 0 db, unless you have special applications that need damping.

bass/treble and DSP adjustments can also be done by software:

- in the trivum control units, under sound settings
- in the trivum web configuration, under setup / output

- with C4 systems: in the web config of the output cards

64. C4 master computer is not reachable after power outage

64.1. Problem

It is possible that old C4 master computers no longer fully start because the clock battery on their main board is empty.

64.2. Solution

Connect a monitor and keyboard to the device. See what is happening on startup. A workaround can be to simply press Enter at the keyboard, to have it fully started. If an error about system time is shown, the full solution is to open the device, and to replace the clock battery.

65. Controller C4 is down although cabling is correct

65.1. Solution

Restart not only the local switch, but also the main router in the network (which makes the internet connection). This may block multicast messages required to communicate with the controller C4.

66. Crestron fails to send commands to trivum after a while

66.1. Problem

If you program Crestron to send HTTP commands to trivum it is important that, after each command, the connection must be closed. If you configure Crestron to keep the connection open then it seems to work for a few commands, but suddenly the connection is closed (a forced close by trivum server after some time) and no further communication seems possible, although sending commands by a web browser still works.

67. DHCP Server cannot be reached

67.1. Problem

The green and red LED of the AudioActuator will stay on permanently with the red LED blinking

shortly inbetween.

67.2. Solution

By default, the device requires a network with a DHCP server to get its IP address. If no DHCP server can be reached, the LEDs behave as described above.

In such a case:

- ask your network administrator to provide a DHCP server
- make sure the trivum device is fully connected to the LAN network so that it can physically reach the DHCP server
- then press reset at the device, or disconnect it from power temporarily for a restart

If DHCP is available at least once then the device can be reconfigured to use static IP in the future. See Using static IP for more information. To do so, download and run the trivum Administration Tool (IP Finder) from <http://service.trivum.com/>

68. Fuse Broken

68.1. Problem

All power connections must be connected, otherwise this error appears.

68.2. Solution

Look for the **Power** - + marks on the actuator and connect both sides to the power supply.

69. Zone is undefined

69.1. Problem

The message Zone is undefined appears, if a TouchPad is using an AudioActuator in Installer Master mode. As a result, the AudioActuator's mode is changed to "Slave".

A direct control of a Slave AudioActuator by TouchPad is not possible. In consequence, the TouchPad loses the connection and zones referenced on that AudioActuator become invalid or undefined.

69.2. Solution

On the TouchPad...

1. Press the trivum icon (upper right corner) to open the **System Menu**.

2. Press [Setup](#) → [TouchPad Settings](#) → [MusicCenter link](#).
3. Select another AudioActuator which is in Master mode.

70. AirPlay unwanted zone activation on track change

70.1. Problem

This happens only on these steps:

1. on iPhone you start AirPlay play to trivum
2. in the trivum App, you switch the zone off
3. the iPhone keeps playing (sound is not audible)

This is a usage conflict. On the trivum side you told that the zone should no longer play. But it is technically impossible to tell the AirPlay client to stop playback. Therefore the iPhone keeps playing.

On the next track change, the iPhone sends another command to start playback, and the zone is switched on again.

The trivum system cannot technically decide which use (from trivum app or AirPlay client) has priority.

70.2. Solution

If you send AirPlay audio to trivum, do not just stop it in the trivum app. You must always go back to the AirPlay sender device, and stop it there.

If this causes permanent conflicts, you may

- disable AirPlay in the zone settings
- enable AirPlay per Streamer module

and then start AirPlay in two steps:

- start sending AirPlay to the trivum streamer (zone does not switch on, nothing audible)
- in a trivum zone matching this streamer, select: music services / airplay / play airplay now

71. AirPlay Startup Errors

71.1. Problem

AirPlay Error: Network (old switch?) uses a unicast .local domain.

This means there is a network configuration that uses a name .local to identify the local DNS domain, which is incompatible to the Bonjour protocol required to use AirPlay. In general this is caused by old router/switch hardware, or wrong configuration within such a switch.

71.2. Solution

- Ask your network administrator to reconfigure the local network NOT to use .local as the local unicast DNS domain name

AND/OR

- to replace the router or switch by a newer or different one

71.3. Aternative

Enter the following at the trivum server:

```
http://serverip/xml/system/fix-airplay.xml
```

It will correct some system internal files trying to work around the problem.

72. WebTouch Visu does not show on a TouchPanel PC in an iframe

72.1. Problem

The trivum WebUI should be shown within an automation UI web application, which embeds it by an iframe.

When running the automation UI, the iframe only contains an error:
"This content is blocked. Contact the site owner to fix the issue."

72.2. Solution

Check the HTML code of the automation UI. It may contain something like:

```
<meta http-equiv="Content-Security-Policy"  
content="default-src 'self' blob: data: ws://192.168.1.100 wss://192.168.1.100;">
```

```
<iframe src="http://192.168.1.200/" width="600" height="400"></iframe>
```

Let's assume that .100 is the IP of the automation UI, and trivum has IP .200. Then this Content-Security-Policy is not sufficient. It must be extended like:

```
<meta http-equiv="Content-Security-Policy"
  content="frame-src 'self' http://192.168.1.200; default-src 'self' blob: data:
ws://192.168.1.100 wss://192.168.1.100;">
```

```
<iframe src="http://192.168.1.200/" width="600" height="400"></iframe>
```

73. WebTouch Visu does not work correctly on TouchPanel PC

73.1. Problem

Things like the **Off**-button at the right bottom, or Alarm Time changes will not work correctly on a WebTouch Visu displayed on a TouchPanel PC with Windows.

73.2. Solution

You must configure the correct Pointer Device **Click Mode** on the TouchPanel PC.

73.2.1. Windows XP/Vista/7

In your Windows System...

1. Click **Start** → **System Settings** → **Pointer Device Settings** → **Click Mode**
2. Select **Click and Move**

By default, there is a wrong mode "interactive touch" selected, which:

- produces a popup menu if you press for a longer time on the Windows desktop
- makes it impossible to switch a zone off by the off button at the right bottom of a web visu
- makes it difficult to change alarm time, as long presses on +/- of alarm do not work

73.2.2. Windows 8

On Windows 8, look for similar settings, and always make sure that a long press does not produce a Windows Popup.

74. Resource sharing conflict

74.1. Problem

Resource sharing conflict appears if

1. an AudioActuator B was a Slave of another AudioActuator A
2. then AudioActuator B's mode was changed to "Installer Master" without unregistering AudioActuator B at AudioActuator A.

74.2. Solution

1. Enter web configuration of primary AudioActuator A
2. Go to **Zones**
3. Delete AudioActuator B from the list of active AudioActuators.

75. Unexpected source (music file/webradio) appears after switching sources

75.1. Problem



Just for C4 systems!

The trivum system has a technical limitation: archive (playlist) playback and web radio playback are using the same source, a StreamingSource Card.

Therefore switching like **Archive Play** → **Local** → **Webradio** means to switch like **StreamSource Card** → **InputConnect** → **StreamSource Card** and when you're back to the same StreamSource Card, all it does is to continue in the playback mode that was active most recently - so if Playlist play was active, it will do this, but if webradio was active, it will play the same web radio again.

The distinction **Play current stream** or run **as internet radio** on Keypad Keys / Commands applies only when selecting the StreamSource Card for the first time after system restart.

76. TuneIn uses wrong city or country location

76.1. Problem

TuneIn tries to auto detect your country by your IP address. If this fails you may enter the latitude/longitude of your city in the trivum server configuration manually.

76.2. Solution

1. Open the web configuration
2. Go to: Music / Streaming / TuneIn / Location
3. Enter the latitude/longitude of your city

Example locations:

- 48.1, 11.5 for Munich, Germany
- 51.5, 0.0 for London, UK
- 48.8, 2.3 for Paris, France

77. Red LED light is permanently active after Software Update on AudioActuator

77.1. Reason 1: Incorrect flashing

When updating with a huge version jump, e. g. from 8.16 to 8.47, it may happen that flashing of internal components does not fully succeed in the first step, and this may cause the red LED to be active permanently although the configuration GUI does not show an error.

77.2. Solution

Repeat the software update (up to 3 times) until the LED goes off after full reboot.

77.3. Reason 2: Jammed reset Button

Another reason can be a jammed reset button.

77.4. Solution

Check if the reset button is somehow locked by the casing. Try to press reset once and check if the system reacts normally.

78. 4Zones Actuator: Voltage too low Alert

78.1. Problem

- No power connected to the lower part of the AudioActuator 4x
If the upper part has no power, the system cannot run at all.

OR

- Fuse broken for the lower part.

OR

- There is power connected, but really too low voltage (it must be 24 V).

HINT: Due to the technical reason, the Voltage too low-Alert will appear on all 4 zones even if the voltage is only too low in 2 zones.

79. simulateKeyPress must be called twice

79.1. Problem

In a Homesever visualization, this command must be called twice to activate a source:

```
/xml/keypad/simulateKeyPress.xml?id=n ...
```

79.1.1. Solution

Append parameter

```
&once
```

otherwise the system waits for a press and then release event and/or key repeats.

80. Group Play with external volume control does not work

80.1. Problem

If the volume of a zone is not controlled by the zone itself, for example in case of an AudioBox with independent Line-Out with RTI controlled amplifier, the audio volume of this zone cannot be controlled by the regular group mechanisms.

81. No sound from some StreamSource cards

81.1. Problem

When using 3 cardhosts with many StreamSource cards (STS) and PowerAmpConnect cards (PAC) be aware of the following restrictions:

- STS (or any source card like RDSTunerSource) must be placed within slots 1-8 of a cardhost only
- PAC can be placed in any slot, but normally they are placed in the higher slots, as the lower ones are used by sources
- sound produced by STS in slots 1-8 of the first cardhost can be played on any PAC in any cardhost
- sound produced by STS in slots 1-8 of the second cardhost can only be played on local PAC within the second cardhost.
Same applies for third or even further cardhosts: sound can only be linked locally within the

cardhost.

This means, for example, that sound from STS in slot 1 of 2nd cardhost can NOT be played on a PAC in the first cardhost.

On a C4 system with 2 cardhosts, these restrictions do not exist, so sound from a STS in the 2nd cardhost can be played on a PAC in the first.

82. Webcam authorization error

82.1. Access by user/password not possible

- Configure your webcam to use HTTP Basic Authorization, but not HTTP Digest authorization.
- the latest Touchpad software will show an error "Webcam digest authorization not supported", older software will only tell "Webcam authorization error".

83. NAS access to a Windows PC share requires username

83.1. Problem

Even if you allowed anonymous network access by "Everyone" to a Windows folder, access is blocked if you leave the username blank.

83.2. Solution

1. Create a new user on your Windows machine, for example with `username=music`, `password=music`
 - Create an easy, simple music folder on your hard disk `C:\TestMusic`
 - Edit the Properties of `C:\TestMusic` and share it on the network with read access for user `music`
 - Enter at the trivum server

```
smb://yourwindowsip/TestMusic
user: music
password: music
```

If you don't know your workgroup then try to type WORKGROUP, or leave it blank.

83.3. Windows 10 firewall issues on share access

If all of the above steps were done, but the music share can still not be accessed:

- configure the Windows Defender Firewall. Go into "enable app or feature", then allow access for the Registration Service ("Anmeldedienst").
- if that doesn't help, deactivate the firewall for public networks.

84. Change audio volume without a slider by defining + and - actions

The trivum web visualization shows a volume level slider which is convenient to use, however, in some cases like very large groups and slow or instable WLAN network the many volume events sent may cause inconvenience in handling.

As an alternative you may define Volume + and - actions:

`Configuration / Zones / zone name / actions / change action / control a zone / Volume + (or -)`

and then touch those actions to increment/decrement volume safely one step.

Furthermore if you feel unsafe about the volume slider going too high set the zone's maximum volume limit to a safe value under

`Configuration / Zones / zone name / basic settings / max. volume for this zone`

you may have to do this for all zones that may take part in a group.

85. How to identify trivum Components by Serialnumber

- C4 System:
 - find the serial number on the C4 Processor card.
This card typically contains an "Eth" LAN connector, a "Fan" connector, and at the right top a small serial number.
 - with software V7, you will not find a valid serial number in the web configuration (there are only dummy values 520 or 12326).
 - with software V8, you may also find the Serialnumber in the web configuration GUI at the top near SNR.
- Audio Actuator and SC: find the serial number
 - printed on the Actuator itself, and
 - in the web configuration GUI at the top after "SNR".

86. SC LED light blink codes or patterns

A basic system status is displayed by the green (upper) and red (lower) status LED directly near the power connector.

The four zone status LEDs right to that are not relevant for the system status.

- Green LED blinking: the MusicCenter software is not reacting for more than 10 seconds. This is normal during startup, as the software needs to start first.
- Green LED on permanently: the MusicCenter software has fully started and is operational. If you still don't see it in the network check network cabling, network switches and ports.
- Red LED blinking: the MusicCenter software is not reacting for more than 60 seconds. If this happens after startup,
 - files on the SD card may be damaged, so MusicCenter is not running
 - you will not see the MusicCenter in the IP finder
 - however, if you still know the IP address, a ping may still be possible, if the operating system is still working.

You may then try a reset to factory defaults as described here:

<https://www.trivum.com/trivum/docs/en/mcenter-manual.html#scfactorydefaults>

87. Actuator LED light blinks with codes or patterns

LED Blink Codes:

- as long as the device is starting, yellow and red flash synchronously once per second
- as soon as the software is fully operational, yellow and green should be flashing, with red being off.



if an actuator is blinking Red, and you press Reset, the red blinking may continue for a while until the device has fully restarted. Please allow one minute after pressing Reset until the blinking stops.

88. The red LED of an Actuator is permanently active on first use

The red LED is on during start phase. If it stays on permanently, please check the following:

By default, the device requires a network with a DHCP server to get its IP address.

If no DHCP server can be reached,

- green and red LED will stay on permanently
- with the red LED blinking shortly inbetween

In such a case,

- ask your network administrator to provide a DHCP server

- make sure the trivum device is fully connected to the LAN network so that it can physically reach the DHCP server
- then press reset at the device, or disconnect it from power temporarily for a restart.

If DHCP is available at least once then the device can be reconfigured to use static IP in the future. To do so, download and run the trivum Administration Tool (IP Finder) from <http://service.trivum.com/>

89. The red LED of an Actuator is permanently active after a Software Update

When updating with a huge version jump, e.g. from 8.16 to 8.47, it may happen that flashing of internal components does not fully succeed in the first step, and this may cause the red LED to be active permanently although the configuration GUI does not show an error.

In this case, repeat the software update (up to 3 times) until the LED goes off after full reboot.

Another reason can be a stuck reset button.

Check if the reset button is somehow locked by the casing, try to press reset once and see if the system reacts normally.

90. RP010 specific LED behaviour on startup

Normal startup behaviour:

- directly after connection to power, the LED is off
- the small LED's at the LAN port should blink first
- after the software fully started, the LED goes green

Special behaviour if the whole infrastructure was taken off power:

- if the RP010 starts with no network connection, because a network switch or router is not started yet, it displays a permanently yellow (or red) light.
Even if the network becomes available after a few minutes, the yellow light stays, and the RP010 gets no connection.

You have then to disconnect only the RP010 from power, and reconnect it.

91. create Windows Desktop Shortcut to Web Visualization

If you defined a web visu under control units, you may create a Windows Desktop Shortcut like:

Google Chrome Browser:

- select "Show" to open a new Browser Window with a web visu.
At the top, you see the address like <http://192.168.1.119/visu/iapp?id=20>
- create a new Tab. enter the same address into that Tab, e.g. <http://192.168.1.119/visu/iapp?id=20>
- look at the right top side for the three dots button.
Select: **More tools / create shortcut**.
Set option: **Open in a new window**.

Now you have a shortcut on your windows desktop that opens without an address bar.

92. How to control multiple Actuators or AudioBoxes via one Web Visualization

To allow this they must be combined as master/slave devices.

- one device stays master (default mode)
- on all other devices: select admin / set mode to installer slave
- on the master, go to the zone list, then wait and reload (via circle button) until all other devices show up in green.
- then select on the other devices: use this actuator

This way the slaves are added to the master as new zones. Then use only the web visualization of the master. There, enter the new zones and play music.



with the 4 zone actuator restrictions in group play apply, for example, starting a group play from a slave zone and then adding zones from the master may not work.

93. Maximum possible Streams (StreamSources) per device

A single C4 system may play

- up to 6 streams in parallel with sample rates up to 96 khz using file formats mp3, aac, alac, flac (16 bit)
- up to 5 streams in parallel with Flac 192 khz 16 bits, or with Flac 96 khz 24 bits (requires Software V 8.67)
- up to 3 streams in parallel with ALAC 192 khz files, or with Flac 192 khz 24 bits (requires Software V 9.41)

Trivum does not support .dsf files or any files with sample rates beyond 192 khz.

94. C4 with 2 or more Cardhosts: Noise or unexpected sound

94.1. Problem

Multiple Card Hosts are used within a large C4 system.

When playing a source, like analogue input, not only the sound of that source is audible, but also unexpected sound like FM tuner. When disconnecting the analogue in source, only the noise is audible.

94.2. Solution:

1. Make sure you are using Shielded Twisted Pair cables.
These are marked as STP or SFTP.
Do not use Unshielded Twisted Pair cables, marked as UTP.
2. Make sure you are using the correct cabling scheme.
For example, with one master and two slave card hosts then connections must be
 - TXA from 1st → RXA of 2nd device
 - TXB from 1st → RXB of 2nd device
 - TXA from 2nd → RXA of 3rd device
 - TXB from 2nd → RXB of 3rd device

95. How to test if a card is broken

95.1. Problem:

A C4 card like FM tuner, Streamsource etc. does not work at all.

95.2. Solution:

Analyze if the problem is caused by the card itself, or by the cardhost, or a specific slot of the cardhost.

1. see if there is another free slot in the same cardhost.
Mind that sources need to be placed in slots 1-8.
If so, put the card in the free slot and restart the system.
 - if it is working then the slot is defective.
 - if it is still not working then the card is defective.
2. if there is no free slot available exchange the card with another card of the same type, for example another FM tuner in another cardhost.

- if the card is working in the other cardhost, but the exchanged card no longer works, then the slot is defective.
- if the card is still not working, even in the other cardhost, then the card is defective.

If the tests clearly show a defective card then give us feedback so we can arrange a replacement.

96. 4 Zone Actuator: Amplifier channel overload

Please check the device temperature under

Zones / left near device select: Show details

If the Temperature line shows more than 65 Degrees this could cause device malfunction.

- make sure that the device gets enough air for cooling.
- look carefully at the device enclosure, near the speaker and power connectors, if there are enclosure caps without holes (gaps) that prevent air circulation.
If so you may remove some or all of these caps.

97. Web Visu Volume Slider Error with Chrome on TouchPanel PC

On a Windows 10 Touchpanel PC the Google Chrome browser is by default configured to react to these gestures:

- swipe right to left: navigate to previous page
- swipe left to right: navigate to next page

This makes a proper use of the Volume slider in the trivum Web Visu impossible.

There is an article in the web under <https://www.404techsupport.com/2014/02/disable-backforward-navigation-swiping-gestures-in-google-chrome-for-windows/>

Basically you have to run the Chrome browser with a parameter `-overscroll-history-navigation=0`.

To do so, create an icon on the Desktop to run the Chrome Browser, then edit it to run something like

```
C:\Program Files (x86)\GoogleChromeApplication\chrome.exe -overscroll-history  
-navigation=0
```

98. number of wires required in a LAN connection cable

- 100 mbit → 4
- Gigabit → 8

99. how to reduce the Web UI elements

If not all functions, like not all sources, should be shown in a web visualization, the following options are available:

- hide FM Tuner:
V9: configuration / actions / define which standard sources should be available
V10: devices / players / tuners / general settings / show tuner as source
- hide Line Input:
V9: configuration / zones / zone / basic settings / Default Line Input
V10: customize / zones / zone / define the default sources / Default Line Input
- restrict visu to a specific zone:
V9: devices / control units / (select visu) / specify possible zones
V10: devices / apps / (select visu) / specify zones which can be controlled
check this, then click on "specify possible zones" that appears
- hide Setup in the web visu: (V9.72 or higher)
V9: system / set up / user interface details
V10: Devices / Apps and Touchpads / Show/hide menus
then select hide 'system setup' in WebTouch clients
- hide a zone from selection by any visu:
V9: configuration / zones / zone / basic settings / zone is available in zone select menu
V10: customize / zones / zone / change visibility of this zone

100. Invalid NAS reply while scanning music files

The NAS uses an old Firmware which is not suitable to scan music files. It returns a wrong reply to "seek" commands used to jump forward and backward within a file, which is required to scan informations from music files.

This means that most or all of the music on a NAS cannot be read. Scanning may still work with .mp3 files using simple ID3v1 tags, but .m4a and other files will not work.

The only solution is to replace the NAS, or to update it's firmware, if an update is available.

101. No sound, no radio reception with FM Tuner

- try a different antenna, at least a simple wire that you plug into the antenna input, for a comparison.
- try a different (non trivum) device with the same antenna cable that you use with trivum, to verify if any reception is possible.
- configure a station with a known frequency, instead of just running the station search. check if it produces a (weak) sound.

102. 4 Zone Actuator Power Supply Connection

Instead of using 2 times a 3.83 A (or more) power supply you may also use a single 7.66 A (or more) power supply, but make sure

- that the + power supply cable is connected by an y parallel cable to both "24 DC +" connectors
- that the - power supply cable is connected by an y parallel cable to both "24 DC -" connectors.

It is not sufficient to wire only one DC+ and one DC- connector.

103. Line Input Auto Sensing: signal without sound too high

103.1. Problem

You connect an external audio source to the analogue line input. When trying auto sensing there is always a high signal although there is no sound.

103.2. Solution

Check if "line input volume adjust" is set to more than 0 db. If so, reduce it.

104. Line Input Auto Sensing with analogue audio: unexpected activation

104.1. Problem

TV is connected by analog audio to trivum, and line input auto sensing is configured. Sometimes

line input activates although the TV is off.

104.2. Reason

1) on the way from tv to trivum there may be electrical interference, like some device switching on or off, inducing signals into the audio line.

2) or the tv is silently switching on temporarily, e.g. for software updates.

104.3. Solution

If the TV also has a digital output, use that. Replace the analogue line by optical, and directly at trivum, use a digital to analogue adapter, which is available at very low prices. <https://www.amazon.com/s?k=d-a+audio+converter>

This eliminates the possibility of electrical inductions, and produces an audio signal only if the TV sends a logical "sound is active" signal via the digital line.

105. Spoken text is very silent, while music plays normal

105.1. Problem

Stereo music is playing at normal volume, but whenever there is spoken text, like news or traffic announcements, it becomes very silent.

105.2. Solution

Check if the + and - wires at one of the speakers were swapped, i.e. "-" of the speaker was connected to "+" at trivum, and vice versa. This could cause centered mono signals like language to be wiped out by inverse sound waves.

106. SC344 or SC340 red or green blinking on startup

The SC34x has a main LED near the power connector.

As long as this is blinking, the main software is not running. This should occur only temporary during startup.

If the LED is blinking red permanently, the software failed to start.

It could be a rare cold start freeze of the system. Try this: - disconnect the power - wait 10 seconds - reconnect the power.

If that does not help, the SD card may be loose in it's socket. Try this:

- open the device (open 4 visible screws around the device)
- take out the SD card
- put it back in

and then retry to start.

The SC344 has small LEDs directly at the LAN connector:

orange must be on permanently, and green must be blinking fast, otherwise there is no full network connection.

107. Device is not reachable by network, fully offline

If there is a master/slave combination of devices, make sure that all are connected by LAN cable to the same network switch.

Change the LAN connection cable from device to the network switch. Change the port used at the network switch.

Take the device from power, wait a moment, reconnect it to power.

Check the LED status of the main LED at the device. If it is permanently red the software may no longer be starting. Report the exact LED behaviour to support.

108. Cannot call trivum Android app from another app

the URL formats for calling the app differ between the iOS and Android version of the app.

iOS: open a web link: `comtrivumcontrol://`

Android: open a web link: `trivum://control`

109. V10 Web Setup Alert: the selected line audio input is not enabled

this happens if you just disable a line audio input, without removing it first as default source in zone(s).

if you want to disable line audio inputs, always do these 2 steps:

- remove them as default line audio input from the zones

- then disable the input

110. trivum Touchpad related articles

111. Some Touchpads freeze after long runtime

Some 7 inch Touchpads may freeze after several days of runtime, requiring to take them from power supply temporarily.

If this occurs, update to software 3.10 build 16887 or higher.

Go into the web configuration under: System / Setup / Advanced.

Run the function "Update system kernel".

Wait until the Touchpad restarted by itself, which may take 5 to 10 minutes.

112. Touchpad has no network connection

Try these steps:

- change the network settings on the touchpad. if static IP is configured, use DHCP, and vice versa. when using DHCP, make sure that your router provides DHCP. on start, the touchpad displays the IP address it uses. check if it has an IP in the same sub network as other devices, e.g. 192.168.178.x or 192.168.1.x
- use a different LAN cable
- use a different port at the network switch
- if possible, try a different network switch model. It should always work with an up-to-date TP-Link 1008P. verify that other devices connected to the same network switch have a working network connection. check the list of incompatible network switches: https://www.trivum.com/trivum/docs/en/trivum-faq.html#_recommended_network_switches
 - + If you use a managed switch, check the POE power settings. A touchpad needs about 3,6 watts, which is POE class 2. Normally POE switch and TP find the correct POE class automatically. However we have seen a case where a POE switch was manually configured to use class 1 only. In that case the TP won't start.
 - + Try a different power supply, for example a power injector versus POE switch.

Also download the trivum ServerAdmin Tool (IP Finder) from service.trivum.com and check on every step if the touchpad appears therein.

113. Touchpad network failure with static IP

ARM9 based touchpads with Software Version 2.42 or lower and static IP configuration may experience network failures, like for example:

- not visible in the music center, server admin tool etc.

- software update cannot be done.

To fix this, follow this procedure:

- check if it's an ARM9 touchpad under settings/touchpad settings/about
- check if it has a Version 2.42 or lower
- and if static IP is configured.

Then you may try to run a software update, but probably it will fail. therefore:

- change the touchpad to DHCP by:

```
- settings/touchpad settings/network
- enable dhcp
- scroll down
- restart touchpad, to activate dhcp settings.
```

- then run a software update, which should work.
- after the update is done, switch back to static IP.
the new version 2.43 or higher will internally write correct network settings with the configured gateway. again select scroll down and restart.

114. How to update Touchpads via the MusicServer

- with V9/V10, select System / Software Update. a list of Touchpads should be shown. go into each one and select: Start update of this Touchpad
- with V8, select Developer / Keypads at the right top, then Update per Touchpad.

115. A webcam image appears and freezes for several seconds on TouchPad

115.1. Problem

An image appears, then the TouchPad freezes for several seconds, then the next image appears.

115.2. Solution

This happens if the webcam image resolution is far too high, e. g. 1280x480.

Reconfigure your webcam to use a lower resolution.

116. Cannot use Touchpad or iPad during group play

116.1. Problem

You can't control your trivum system while playing audio in a group.

116.2. Solution

This is relevant with Installer Line products like FLEX, REG, DESIGN (AudioBox).

Please read the following article on software versions and network switch configuration: [No sound on group play with many devices](#)

116.3. TouchPad alarm icon shows no time

The time is shown only if there will be an alarm within the next 24 hours.

117. TouchPad time differs from trivum Server

If you want the Touchpad to receive its time from the trivum Server, make sure that NTP is disabled locally on the Touchpad:

On the TouchPad...

1. Press the trivum icon (upper right corner) to open the **System Menu**.
2. Press **Info**.
3. Scroll down the table **Informations**.
4. Press **Special settings**
 - Enter manually `ntp off`

If you want the Touchpad to use NTP, but it always displays GMT time, then the time zone infos have not been installed yet. To solve this issue, run a software update:

On the TouchPad...

1. Press the trivum icon (upper right corner) to open the **System Menu**.
2. Press **Setup** → **Online software update**.

118. TouchPad cannot be opened by web browser

118.1. Problem

The trivum 4.3" TouchPad WebSetup cannot be opened by a web browser.

118.2. Solution

Check the TouchPad IP:

1. Press the trivum icon (upper right corner) to open the System Menu
2. Press Info
→ The TouchPad IP is displayed in the left Informations area
3. Compare this IP to the IP of your Computer from which you want to access the TouchPad. The first three parts of the IP should be identical.

```
Computer-IP: 192.168.1.30
TouchPad-IP: 192.168.5.50
```

Example: Bad. Connection is probably not possible, as TouchPad is in a different subnet (.5) than computer (.1)

```
Computer-IP: 192.168.1.30
TouchPad-IP: 192.168.1.50
```

Example: Good. Connection should be possible.

118.3. Special case

If the TouchPad has an IP 169.254.231.13, then it probably failed to get a DNS address from a DNS server.

- check if any DNS server at all exists in the LAN
- check if TouchPad has connection to that server

OR

- configure TouchPad to use a static IP address.

In such a case, high addresses like .190 are recommended to avoid later conflicts with future DNS servers that typically use low area IP's.

119. TouchPad does not accept touch presses in some areas

119.1. Problem

The trivum TouchPad does not react to touch press in some places of the screen.

119.2. Solution

Run a touch sensor test:

Settings / Touchpad settings / Advanced / Run touch sensor test

You get a blank screen. Wherever you touch, it should show a red dot. If there are areas where no red dot is shown, then there is a defect at the touch sensor, and the Touchpad needs to be sent to trivum for repair. To stop the test, touch it with two fingers for five seconds.

120. TouchPad does not accept touch presses anywhere

120.1. Problem

The trivum TouchPad does not react to any touch press, but everything else (music status display etc.) seems normal.

A cold restart (by power disconnect) doesn't help as well.

120.2. Solution

Possibly a display connector inside the trivum TouchPad got loose.

1. Check the inside display connector
2. Remove the cover (8 screws)
3. Check display connector (foil conductor, foil connector)
 1. g. by opening the retainer, then remove the connector, plug it in again, close the retainer
4. Check if the TouchPad is working correct.

121. RGB dimmer color wheel is not shown on TouchPad

121.1. Problem

The RGB dimmer color wheel is not shown on KNX TouchPad.

121.2. Solution

- Touch the dimmer object in the KNX page, and keep it touched for 3-5 seconds.
→ The color wheel popup should be shown then.

122. No webcam image appears on TouchPad

122.1. Problem

If you open the webcam App in the TouchPad's KNX pages, there is no image.

122.2. Solution

- Make sure the TouchPad SW version is 1.69 or higher
older versions send fixed authentication data (user="admin", password="1234") that can be misunderstood by webcams
- Check if the camera allows anonymous access
If not, enter webcam username and password in the trivum webcam configuration (The password field appears as soon as the user name is set.)
- Check if the camera allows parallel access by multiple clients. Maybe it allows only single client access. This might block the access of the TouchPad, because the image is already shown in a web browser.
Create an empty tab in your web browser and open the camera image URL therein, to make sure it actually delivers JPEG images.
- You might have to restart the TouchPad. However in most cases this shouldn't be necessary if the configuration data is correct.

123. cannot delete web radio favourite with touchpad

There is a problem with web radios which are no longer supported by TuneIn, marked as "Not supported". These may fail to delete with the Touchpad. Try it with the web visualization instead, this should always work.

123.1. 7 inch touchpad compatible POE switches

POE Switches for power supply:

do NOT use:

- TP-Link TL-SF 1008P Rev. 1.6 (Revision 3 works)
- D-Link DGS-1008P Rev. B1 (technically same as TL-SF above)

otherwise the power supply is too weak, and the touchpad may start only a few seconds, then switch off.

Power works normal with:

- TP-Link TL-SF 1008P Rev. 3
- HP 1920
- Intellinet 524155

123.2. 7 inch touchpad startup failure

Problem: when connecting power there is a short white flash, then (with a black screen) background light is active, but (for longer than a minute) no activity is visible. Ethernet network LEDs also do not blink.

Solution: look at the LEDs at the network switch where the touchpad is connected. When connecting power at the touchpad, orange should be on permanently, and green should start to blink after a few seconds. If there is no blinking, then the SD card in the touchpad may have got loose during transport. Open the device (by 4 screws) then search for the sd card. Take it out, and push it in again. Then reconnect the device to power. == maximum number of webcams with trivium touchpad

The trivium A13 Touchpad supports up to 8 web cams, with resolution 320x240, and one image update every 5 seconds.

The trivium ARM9 Touchpad supports up to 4 web cams, with resolution 320x240, and one image update every 5 seconds.

If higher resolutions or more frequent updates are used then less web cams will work.

124. Touchpad: no rows/system/data found error

This error occurs when the TouchPad is connected to a wrong server. This might be caused if the TouchPad was correctly connected to a machine 192.168.1.119 but the next day the machine changed it's IP and now .119 is a different (non trivium) system.

Solution:

On the TouchPad...

1. Press the trivum icon (upper right corner) to open the **System Menu**.
2. Press **Setup / TouchPad Settings / MusicCenter link**.
3. Select the trivum server again.

125. Music purchased through iTunes cannot be synchronized to the trivum System

125.1. Problem

Music purchased through iTunes cannot be synchronized to the trivum System, showing an error file too short, skipping.

Possible reason: If you purchased the music through AppleTV, it is possible that it isn't synchronized yet to your local apple machine where your music library tracks are stored normally. In this case, you have to synchronize AppleTV manually with your apple server (PC, notebook) to make those tracks fully available for synchronization.

125.2. Solution

Check the downloaded music tracks

1. Open iTunes
2. Select your newly imported or purchased music track
3. Right-click on this Track to open the context menu
4. Select **Get Info**
5. Check the size field

→ A real, complete music file usually contains multiple MB of data.

→ If you see only a very small size (smaller than 32768 Bytes) then this is no valid music file, but either a damaged file, or some kind of reference to a track that trivum cannot use.

In this case, try to play the track in iTunes. If playing succeeds, check the size again - if it's now several MB, then iTunes did some internal on-demand download action.

If you checked your new files this way, making sure that every track has a reasonable size, you may create a new playlist, drag them therein, then synchronize and check this playlist in the trivum system. The trivum Sync tool will create a statistic for this playlist listing how many tracks were valid for synchronization.

126. iTunes database on NAS does not use Library.xml

126.1. Problem

When creating an iTunes database directly on the NAS as described in here then iTunes will store all song information in a file: iTunes Library.xml

If, however, such a file does not exist on a NAS, check this:

1. if you instead find an .itl file enable the creation of .xml format, within iTunes, under:

Preferences / Advanced / Share iTunes Library XML with other applications

1. if you instead find a file Mediathek.xml with contents looking similar to an iTunes database, then this is no live database! It is just a manually exported copy or backup, created in iTunes by: File → Library → Export Library. trivum does not use this file for good reason, as it will never be updated if the user changes his playlists within iTunes.

126.2. Solution

1. Create a real iTunes library on the NAS as described here: [NAS and iTunes](#)
2. Delete the `Library.xml`-File

127. Known issues with V8/C4 systems only

128. Zone Actions cannot be edited

128.1. Solution

1. You have to enable the expert mode:
2. Open the Multiroom Setup Tool
3. Click `System → Basic Setup`
4. Activate `Use expert mode for configuration`

129. RS232 Adapter can be listed but not connected/programmed

RS232 Adapters were used only up to software V8.

Check your network switch if "IGMP Snooping" is active. The trivum IrTool Software uses Multicast messages to send commands to the adapter, but so far it does not use the IGMP protocol. Disable IGMP Snooping at your switch (e.g. within D-Link DGS 1100-16 under "L2 Features") and it should work.



however, that if you are ALSO using trivum Actuators with synchronized audio play back AND a WLAN, then IGMP Snooping must be active, so the above deactivation should be temporary for programming only.

130. IR/RS232 Adapter power supply connection

Possible options for power supply:

- A POE switch that delivers 48 V via CAT 5 cable

OR

- A CAT 5 Power Injector, which itself is connected to a 48 Volts power supply.



never connect this 48 Volts power supply directly to the adapter!

OR

- A 15 (!) Volt Power supply connected directly to the IR/RS232 adapter.

131. How to trace IR/RS232 Adapter communication

If a device connected by IR/RS232 adapter does not react, follow these steps to trace the communication:

131.1. activate device I/O tracing at server side

System V7: select **Addons / Devices / open device**, then **advanced / verboseMode**

Then send test commands: **Addons / Devices / open device**, select **Commands**, select **Send** at the left side.

Then open in the web browser:

```
http://{serverip}/print/controller-trace
```

If you see messages like:

```
<< send: "MYCOMMAND {0D}{0A}"
```

this means a command was SENT to the Adapter, and the Adapter tried to forward to the device.

If you see messages like:

```
>> recv:
```

this means a response was received from the device.

If responses are listed, however, also depend on the kind of device driver chosen. Unidirectional drivers may never list a response.

In such a case, the following may help:

131.2. trace communication directly at the Adapter

To do so, find out * the IR/RS232 Adapter IP address * the IR/RS232 Adapter Serial Number * the IR/RS232 Adapter Firmware Version

System V7: IP and SNr are listed under **Addons / Devices** in the Status column.

Firmware Version is listed under **Adapters**.

Then download the trivum trace tool from <https://www.trivum.com/trivum/docs/de/tools-overview.html>

Windows: download `trace.exe` AND `libgcc_s_dw2-1.dll` **Mac :** download `trace-mac`

Then open a Shell or Command Line Window (e.g. Windows: select Run then type CMD.exe) and go into the folder of the downloaded tools.

- RS232 Adapter Version 1.12 and lower:
 - Windows: type: `trace adapterip`
 - Mac : type: `chmod 777 trace-mac`, then: `./trace-mac adapterip`
Now you should see something like

```
Tracing: 192.168.1.133
trivum TraceMonitor V1.08 (Port=1222 Target=192.168.1.133, VMar 14 2013/11:11:41)
```

and you may press

```
'i' for information
't' to toggle event tracing outputs
```

- IR+RS232 Adapter Version 1.13 and higher:
Make sure you are using trace tool 1.09 or higher, otherwise you cannot trace the adapter.

- Windows: type: trace ir adapterSerialNumber
- Mac : type: chmod 777 trace-mac then: ./trace-mac ir adapterSerialNumber
no interactive options are available.

131.3. control the device manually

Instead of sending commands via trivum to the device, also try to control the device directly, e.g. by switching on a DVD player by it's power key, then loading a DVD and skipping tracks manually, to produce possible RS232 replies that may show up in traces as described above.

131.4. Typical RS232 Adapter replies

depending on the adapter firmware, more or less informations are shown.

131.4.1. RS232 Adapter V 1.03 examples:

```
Got cmd #64
-> means adapter got an RS232 command
    from the trivum server which will be
    forwarded to the actual RS232 device.
```

```
Sent message to device
-> typically after cmd #64, the command
    was sent to the actual RS232 device.
```

```
Got cmd #67
-> means adapter got an AdapterInfo request
```

```
Sent device reply to controller {IP}
-> means adapter got data from the actual
    RS232 device and sends it to the server
```

This firmware allows interactive 'i' command to check some cable pin status.

132. Devices at IR/RS232 Adapter do not react

Devices are configured at the trivum server and connected via RS-232 adapter.

132.1. Adapter is not active, not found in network

1. Check the Adapter power supply and LAN cabling.
2. Check the Cat-5 LAN connector
 - If LEDs are blinking, then both power supply and LAN connection is working

132.2. Adapters are detected

Adapters are detected, devices can be activated by TouchPad or web keypad, but they do not physically react, and errors show up like:

- does not get any data from device
- does not get valid data from device
- device noanswer
 1. Enter the device overview page.
 - Adapters should appear in one of three colors:
 2. *green*
Adapter is active, has sent messages to device AND received replies from the device
 3. *red*
adapter is not active at all (showing "0/0") OR has communication problems (e. g. IP range too small, OR other device like a TouchPad using an IP within the IP range that conflicts with adapter).
 4. *blue*
adapter is active, but the device never sends a reply. There is an info (n/0) meaning
n = number of sent messages
0 = number of received messages
 - if the device is bi-directional, meaning it should sent replies to trivum, then the physical connection does not work. In this case, check the cabling.

132.3. Possible test

To check if the adapter is physically able to receive any data:

1. unplug the RS-232 from the target device
2. connect (shortcut) RX and TX lines, so the adapter receives it's own RS-232 commands.
 - The receive count must then go up

132.4. Connection from RS-232 adapter to device

Within the cable, TX/RX lines must be crossed. The pin number for TX/RX is different from device to device. Cable pin layouts on the trivum connector side are documented in <http://www.trivum.de/downloads/documents/MusicCenter-V7-Setup.pdf>

trivum side RS-232 connector pins

		plain RJ-45	SUB-D9 adapter i-rj45
1	TX (Output)	orange/white	blue
2	GND	orange	orange
3	RX (Input)	green/white	black
[6]	[GND]	green	

Pin 6 of plain RJ-45 will no longer be used in future adapter versions.

target device side connector pins

The kind of connectors vary from device to device, and even when using SUB-D9 connectors pin assignments can change from device to device. Therefore consult the device manual for an exact pin assignment description.

how to connect

The TX/RX lines must be crossed.

- connect trivum TX to device RX
- connect trivum RX to device TX
- connect trivum GND to device GND

When measuring the TX line it should show -5 to -9 volts.

Table 1. Adapter cables available from trivum

part number	type
i-loewe-c*	RJ-45 o RJ-12 to connect Loewe TV's
500018	generic RJ-45 to Sub-D9 kit (2 parts) that allows to configure pin assignments individually

* No longer be available.

If you can send commands to the device, e. g. you press track skip on the TouchPad and a DVD player actually skips to the next track, but you still see the error no valid data on the TouchPad, then since V7.76/8.17 there is also an option in the advanced device settings to disable device reply warnings. This, however, should be used only if you are absolutely sure that the device is connected and reacts to commands. The message device has no connection cannot be disabled. See also Tracing IR/RS232 Adapter communication.

133. Known issues with old system configurations

133.1. TIDAL account update required from 09.11.20

If you have a TIDAL account configured by just entering username and password at trivum, then this is an old method which can no longer play music from November 9th, 2020.

You then have to do these steps:

1. Update to software V9.61 or higher.

2. Go into the setup of your trivum device.

Go to "Music / Streaming", and into the TIDAL account setting. There you will find a message "Complete this account". Click on that, and follow the instructions to upgrade your account configuration to web based authentication.

During this process, you will be redirected to the TIDAL website, where you enter your TIDAL account data. Then you change back to the trivum web page, and click "complete".

133.2. Spotify access shows error: need premium account

Spotify accounts configured directly on devices were officially **discontinued by the Spotify company on 16.05.2022**. If you had this configured, older software shows a wrong error message "need premium account", although the accounts are premium. From Software 9.73 build 16269 there will be a corrected error message: "No service. Please use Spotify Connect."

Therefore **use Spotify Connect instead**. Install the Spotify App on a music control device, like a mobile device or PC, then select trivum as the playback device. Once music is selected and playback started, there is no need to keep your control device running. E.g. you may close Spotify on the PC, the music will continue to play. However, to change music selection later, you have to run the Spotify app again.

If you prefer accounts directly on the device, a good alternative are TIDAL, Deezer and Qobuz.

With TIDAL, even Family accounts with separate user/password per family member are possible, allowing to configure them all on your trivum device.

With Deezer, this is also possible meanwhile, but it requires an extra step done by through the Family admin account, who has to convert the family member accounts into independent ones, with separate password. Read more here:

<https://support.deezer.com/hc/en-gb/articles/206096901-Log-In-To-Deezer-Family>

134. Coverart does not show in Audioplayer screen

134.1. Problem

After a System V8 (e. g. AudioActuator) software upgrade to V90, it can happen that music is listed

with cover art in the artist/album search, but when playing one of these tracks, the player screen does not show cover art.

134.2. Solution

- In the trivum Setup, select to clear the whole music DB (with all cover art)
- Rescan everything.

135. Known issues with old software versions

135.1. Web Radio or Audio Service stream interrupted after some time

Although one reason can be the server which provides the audio, there is one known software issue, which is fixed with V9.82, or V10.10.

Therefore, if you have a software older then that, please update.

135.2. Web Radio stations do not play

Update your trivum system to the latest V9 or V10 software to correct this.

If your system has V8 software, it is highly recommended to update to V9.

If you don't want to do this, because of C4 device control, you may

- set: Basic Setup / Use alpha/beta versions
- set: Basic Setup / Use nightly build versions

then update to V8.85. But be aware that web radio stations may become incompatible again any time in the future, and then fixes may be available for V9 only.

135.3. AirPlay with iOS9 requires V8.68 software or higher.

AirPlay produced by iOS9 iPhones or iPads requires at least trivum software version v8.68.

135.4. AirPlay problem with C4 on 2nd, 3rd streamsource card:

The zone will not switch on unless you update to V8.73 beta build 11441.

135.5. Spotify App cannot be opened from within the trivum iOS App

Update the trivum app to version 2.6.1.

Please note that right now even app 2.6.1 shows a version 2.6.0 at the bottom of the screen, so refer only to the version shown in the App Store. This will be fixed in the future.

135.6. No sound on group play with SC and AudioBox P150 devices

It could happen that there was no sound in slave zones of groups during group play on these devices. Update to V9.63 build 15387 or higher to fix this.

136. Weather forecast requires Touchpad V2.11.

Due to a change of the weather forecast provider it is required to update the Touchpads, as described in the following:

137. Empty Web Visualization with iOS 9.3.5 iPad, iPhone, Safari browser

If this occurs update your trivum server to v8.75 beta build 11952 or v9.05 nightly build 11952. If your system still runs software version 6 or 7 please contact trivum support.

138. RPx actuators: if unexpected restarts occur:

Update to the latest Beta build 11520 or higher.

138.1. Cannot search in the trivum Android app

If you want to search, for example, tunein stations, but the text entry field shows no keyboard:

- do a long touch into the entry field
- or update to V9.74 build 16605 or higher.

138.2. trivum Android app volume control not reachable

This can happen after activating the app from standby. As a workaround, do these steps:

- press the 3-stripes button at the right top for 2 seconds, until the ui is reloaded
- or turn your mobile 90 degrees to the right, then back.

or update to V9.75 build 16865 or higher.

138.3. No sound with newer SC344m devices

Make sure you have software 9.74 build 16584 or higher.

138.4. direct software update not possible with some devices delivered in autumn 2022

If you have a trivum device running with Software V9.74 build 16617 to 16664, and option "Use release software" is not set in the update menu, you will not be able to set that anymore. Trying so creates an error "attribute OptionAlphaSoftware not known". This makes it impossible to update to the latest software directly.

138.4.1. Solution: update twice

Run a first software update on the archive channel. It will install a software V9.77 or higher which does not contain the setup error.

Then go into Software Update.

Select: **Use release software.**

Select: **Use latest software.**

Then run a second update. It will install the latest software.

138.5. Touch control does not work in the web user interface

If music selection by touch does not work:

- in the Web UI on iPad (standalone browser)
- or on a touch panel PC

update your system to software V9.50 or higher, where the Web UI was fully reworked.

138.6. trivum App for iOS V2.5.0 cannot be used with old iOS versions

Update the App to the current version 2.5.1 to fix this.

138.7. No control on iPad with old V8 software and iOS 15.4

If you have a trivum system with old V8.x software, control on the iPad by trivum app or Safari web browser may not work. As a workaround, install the Google Chrome browser on the iPad, then enter the trivum IP there.

138.8. V8 systems WebUI failure

Since iOS 15.4 it can happen that the WebUI shows a permanent blue bar with connection failure. Update to V8.84 to fix this.

On some devices a touch of WebUI actions may not do anything. As a workaround, open a Chrome browser on your iPad, then type therein `trivumip/visu/iapp`

139. /xml/zone/runCommand.xml for TuneIn Favorites does not work

139.1. Problem

Since V8.53 there is a page print example commands listing command ID's for external visualisation. Unfortunately, until V8.56 this page documented four internal commands as select TuneIn favorites 1 to 4:

```
/xml/zone/runCommand.xml?zone=@0&command=56  
/xml/zone/runCommand.xml?zone=@0&command=57  
/xml/zone/runCommand.xml?zone=@0&command=58  
/xml/zone/runCommand.xml?zone=@0&command=59
```

From V8.57 on these commands no longer select TuneIn favorites, but line inputs.

139.2. Solution

If you use one of these commands, replace them by:

```
/xml/zone/set.xml?zone=@0&source=@i1  
/xml/zone/set.xml?zone=@0&source=@i2  
/xml/zone/set.xml?zone=@0&source=@i3
```

The "@i" syntax however allows to select more than 4 favourites directly.

140. Static IP cannot be configured with AudioActuator

140.1. Problem

Full support for static IP is available only from Software Version 8.29. If you update to 8.29 you may have to run the update twice.

140.2. Solution:

To find the static IP settings, follow these steps (V 8.49 or higher):

1. Open the Multiroom Setup Tool.
2. Click System → Basic Setup
3. Activate Use expert mode for configuration
→ Further expert mode settings for this installation will be displayed.
4. Activate Use static Ip instead of DHCP

141. Further reading

141.1. Gira HomeServer and QuadClient issues

Find more in the MusicCenter manual here: https://www.trivum.com/trivum/docs/en/mcenter-manual.html#_gira_homeserver_notes

142. Appendix

142.1. AirPlay message analysis with sfk.exe

You can check if AirPlay Input announcement messages are visible in your network segment. For example, you may use the command line tool sfk for further analysis.

- download sfk.exe from <https://www.trivum.com/trivum/docs/de/tools-overview.html> and store it in a folder like `C:\trivum`
- under Windows, open a command line (CMD.EXE)
- in the command line, type:

```
C:
cd \trivum
sfk udpdump -bonjour
```

Then you should see messages like:

```
[#001 received 295 bytes from 192.168.1.119]
>00008400 ... 6976756D< ..... 94ACCA02B026@trivum 00000000
>3A202331 ... 616C0000< : #119 Room 4._raop._tcp.local.. 00000020
>21800100 ... 4F001C80< !.....x.....twister-8.8.0... 00000040
>01000000 ... 01000000< ....x..... .0..... 00000060
>780004C0 ... 20233131< x.....w 94ACCA02B023@trivum: #11 00000080
>3920526F ... 1F393441< 9 Room 2.-.!.....x.....0.94A 000000A0
>43434130 ... C02D0021< CCA02B021@trivum: #119 Kuche.-.! 000000C0
>80010000 ... 30407472< .....x.....0"94ACCA02B020@tr 000000E0
>6976756D ... 78000800< ivum: #119 Schlafen.-.!.....x... 00000100
```

which contain a binary data dump, also shown as text.

Please note: make sure the messages contain "_raop" and the expected AirPlay input names. Otherwise they can just be MDNS messages, which are not related to AirPlay.

If you see messages containing "@trivum" with the expected input names, then these are AirPlay input announcements by a trivum server.

If you see no messages at all, but there must be (also non trivum) AirPlay devices in the network, open CMD.EXE as administrator and check your Windows Firewall settings.

If you see far too many AirPlay messages, you may filter like

```
sfk udpdump -bonjour -from=192.168.1.119
```

which will show only messages from IP address 192.168.1.119.

If the trivum server seems to send nothing:

1. Open the Multiroom Setup Tool.
2. Click Admin → Quick Restart

→ The trivum server must send those announcements on restart.

If you see Bonjour messages by non trivum devices, but not trivum:

Check carefully if these messages are really AirPlay input announcements, i.e. they contain "_raop" and the expected input names.

Otherwise they may just be MDNS messages, and the other device is also not able to send AirPlay names.

142.2. SpotifyConnect message analysis with sfk.exe

While the Spotify App is in use, you can check if trivum sends Spotify Connect Input announcement messages. For example, you may use the command line tool sfk for further analysis.

- download sfk.exe from <https://www.trivum.com/trivum/docs/de/tools-overview.html> and store it in a folder like `C:\trivum`
- under Windows, open a command line (CMD.EXE)
- in the command line, type:

```
C:
cd \trivum
sfk udpdump -bonjour
```

IF your PC is connected by LAN cable to the same network switch as trivum, (and ideally it is a simple unmanaged switch like TP-Link 1008P), you will see messages like

```
[#012 received 205 bytes from 192.168.1.54 port 5353]
>00008400 00000002 00000003 105F7370< ....._sp 00000000
>6F746966 792D636F 6E6E6563 74045F74< otify-connect._t 00000010
>6370056C 6F63616C 00000C00 01000000< cp.local..... 00000020
>3C001310 30323831 36386233 38633566< <...028168b38c5f 00000030
>30312D30 C00C095F 73657276 69636573< 01-0..._services 00000040
>075F646E 732D7364 045F7564 70C02200< ._dns-sd._udp.". 00000050
```

In this example, if IP 192.168.1.54 belongs to a trivum device, you see that somehow Spotify Connect inputs are announced by that device. (Exact input names are not visible that way)

If you see no messages at all, but there must be (also non trivum) Spotify Connect devices in the network, open CMD.EXE as administrator and/or check your Windows Firewall settings.

If you see far too many bonjour protocol messages, you may filter like

```
sfk udpdump -bonjour -from=192.168.1.54
```

which will show only messages from IP address 192.168.1.54, or

```
sfk udpdump -bonjour -data "@spotify"
```

which will show only messages containing the text "@spotify".